14

LYMPHOID MALIGNANCIES

MICHAEL TEITELL

Department of Pathology, David Geffen School of Medicine at University of California—Los Angeles, Los Angeles, California

PIER PAOLO PANDOLFI

Molecular Biology Program and Department of Pathology, Memorial Sloan Kettering Cancer Center, New York, New York

Malignant transformation may occur at any point during lymphoid cell maturation, resulting in stage- and lineage-specific cancers of the immune system. Many in-bred and engineered mouse strains develop specific lymphoid cancers, providing potentially useful models of human malignancy with insight for pathogenetic mechanisms. Newer techniques, targeting dysregulated gene expression to specific developmental stages portend newer, more accurate mouse models in the future. These models will likely have an increasing role in evaluating targeted therapeutic strategies for efficacy.

INTRODUCTION

Mammals rely on lymphocytes and dendritic cells for protection from pathologic processes such as infection and cancer. Unfortunately, transformation may occur at any point during lymphoid cell maturation, resulting in stage-specific malignancies. Tumor susceptibility seems to depend on specific genetic or epigenetic errors, host background, and immune status. Many in-bred and engineered mouse strains develop lymphoid cancer, providing potentially useful models for human malignancy. Desirable models tend to recapitulate the origin, progression, and outcome of comparable human diseases. In this chapter we briefly review lymphoid cell development as a framework for discussions on tumor analysis and classification schemes, followed by examples of genetically engineered models of lymphoid cancer in mice. Many

excellent reviews on lymphoid cell development in mice and humans are available (see captions for Figs. 14.1 and 14.2).

LYMPHOID CELL DEVELOPMENT IN MICE

Postfetal lymphoid cells originate from renewable hematopoietic stem cells (HSCs) in the bone marrow (BM [1–4]). According to current models of hematopoiesis, HSC-derived common lymphoid progenitors (CLPs) develop into B, T, natural killer (NK), and NK/T cells while common myeloid progenitors (CMPs; see Chapter 17) yield erythrocytes, granulocytes, megakaryocytes, and monocytes [5, 6]. CLPs and CMPs, or a dendritic cell (DC) precursor, develop into lymphoid- and myeloid-dendritic cells, respectively [7–10].

B-Cell Development

Stages in B-cell maturation are marked by specific patterns of gene expression, protein expression and immunoglobulin (Ig) gene rearrangements (Fig. 14.1 [11–13]). These stages are controlled by key transcription factors that are expressed in response to signals from the environment [14–18]. In the BM, Ikaros and titrated levels of PU.1[•] expression enable HSC-to-CLP differentiation [19]. B-lineage development is then guided by early B-cell factor (EBF) and E2A gene splice variants

• Q3

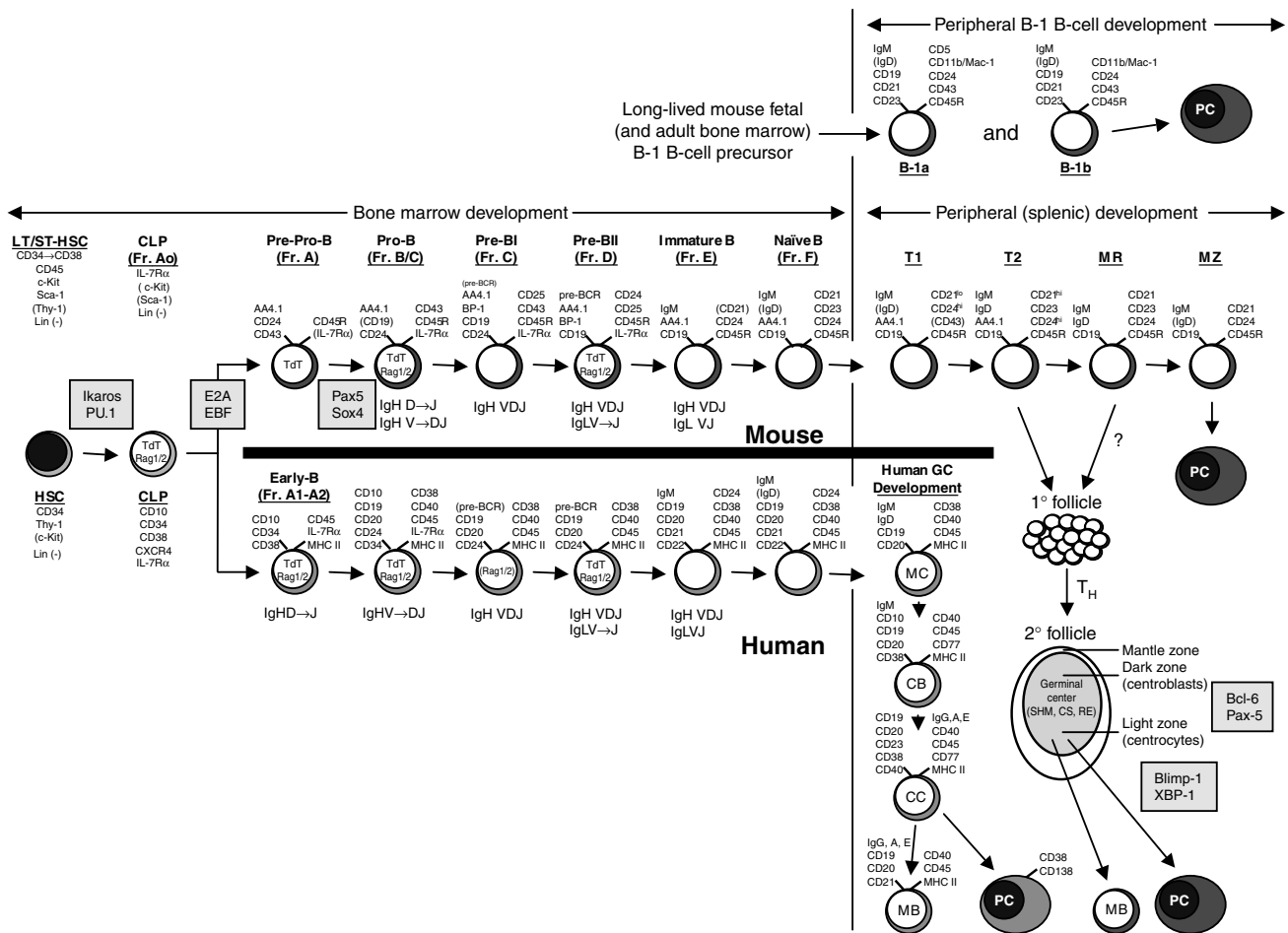

• Q1 **Figure 14.1.** Mouse and human (below thick line) bone marrow and peripheral B-cell development. Useful cell surface, cytoplasmic, and nuclear stage-specific proteins are shown, along with essential mouse transcription factors (boxed in yellow). (Adapted from Refs. 2, 3, 12–14, 43, and 381–384.) Malignant transformation at distinct developmental stages yields characteristic patterns of protein expression. Mouse developmental stages are from Hardy and Melchers [12, 382]. LT/ST-HSC, long-term/short-term hematopoietic stem cell; CLP, common lymphoid precursor; T1, transitional 1; T2, transitional 2; MR, mature, recirculating B cell; MZ, marginal zone B cell; T_H, T cell help; SHM, somatic hypermutation; CS, class switch recombination; RE, receptor editing; MC, naive mantle cell; CB, centroblast; CC, centrocyte; MB, memory B cell; PC, plasma cell.

E12 and E47 during the CLP-to-pre-pro-B-cell transition [20–22]. Pre-pro-B cells retain myeloid potential, which is abolished by subsequent expression of the B-lineage commitment factor Pax5 [23, 24]. Following successful immunoglobulin heavy-chain (IgH) gene rearrangements, pro-B cells transition to pre-B cells expressing the surface pre-B-cell receptor (BCR [14, 25]). With subsequent Ig kappa (Igκ) or lambda (Igλ) light-chain (IgL) gene rearrangements and expression, pre-B cells develop into immature/naive B cells that coexpress surface IgM and IgD receptors.

IgM+/IgD+ coexpressing B cells enter the circulation and home to the splenic white pulp as transitional

(T1) B cells. T1 B cells develop into T2 and then mature naive B cells under the influence of local splenic factors and antigen-dependent selection [26–30]. Mature naive B cells recirculate and populate lymphoid tissues such as lymph nodes, intestinal Peyer patches, and the spleen. Intraorgan localization of these immigrant B cells depends on specific molecular signals from the local microenvironment [31–37]. In the spleen, mature naive B cells reside in clusters called primary follicles within the white pulp. Additional seeded B cells stop recirculating and populate a thin marginal zone (MZB) at the outer edges of the white pulp [38]. MZBs develop directly into plasma cells and mainly participate

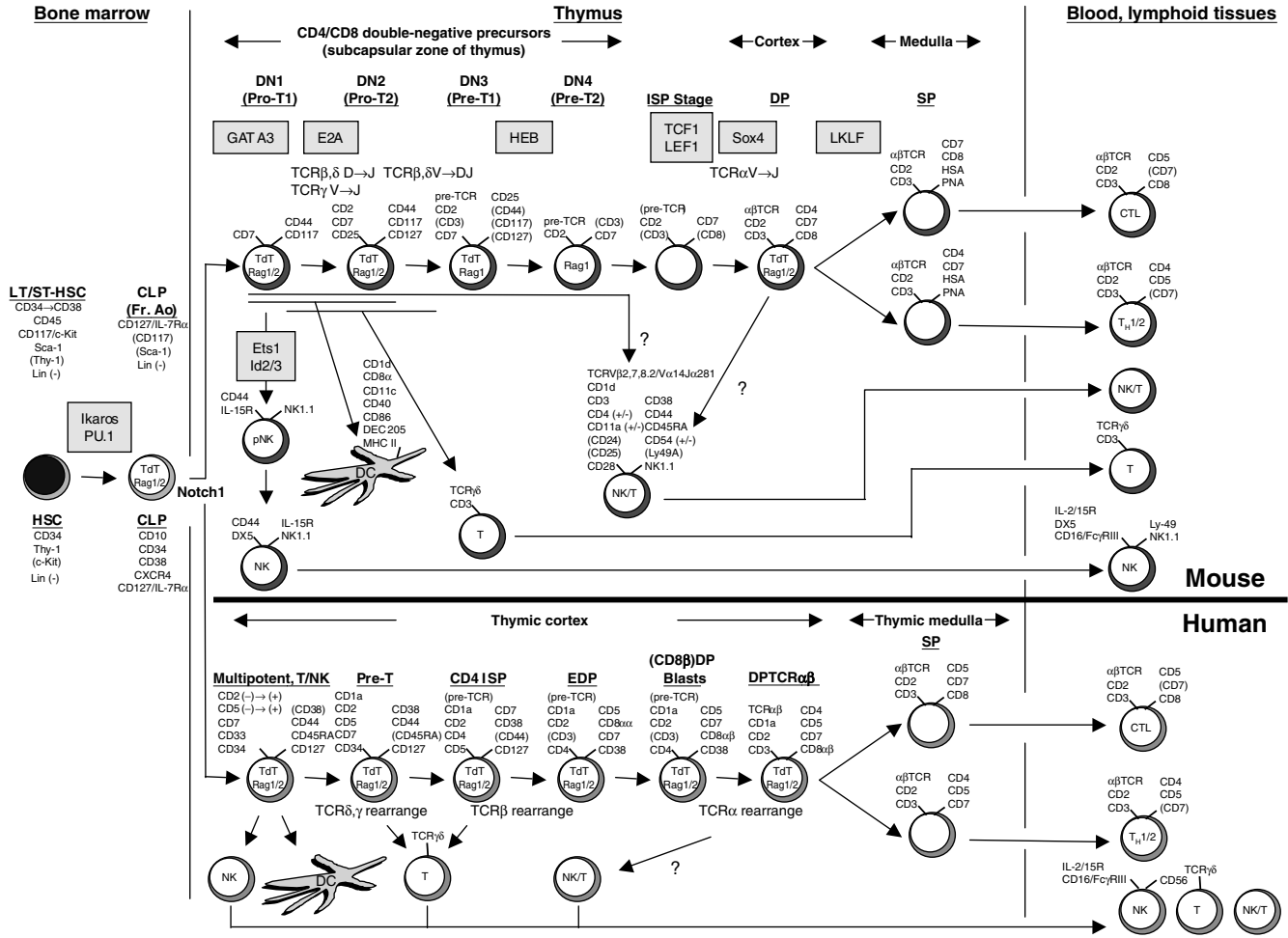

Figure 14.2. T, NK, NK/T, and DC development in mouse (above thick line) and human thymus. Precursor cells for some myeloid cell types may also be contained within the DN1 (Pro-T1) population [53, 54]. (Mouse T-lineage development is adapted from Refs. 20, 61, 62, 69, and 384–386. Mouse NK-lineage development is adapted from Refs. 20, 69, and 84–87. Mouse NK/T-lineage development is adapted from Refs. 99, 100, 102, and 103. Human T-lineage development is adapted from Refs. 72–76.) Essential mouse transcription factors are listed (in yellow boxes). Malignant transformation at distinct developmental stages yields characteristic patterns of protein expression.

in front-line T-independent antigenic responses, while primary follicular B cells form secondary follicles under stimulation of T-dependent antigens. Secondary follicles exhibit a mantle zone of nonresponders and a germinal center (GC) of responding B cells undergoing expansion coupled to antibody refinement and selection [39–42]. Large, cycling centroblasts occupying the GC dark zone progress to small, noncycling centrocytes of the GC light zone. Surviving centrocytes yield high-affinity, class-switched, and somatically mutated Ig-secreting plasma cells and memory B cells. These GC emigrants either take up residence in interfollicular regions of the spleen or recirculate to populate additional hematopoietic organs such as the BM. As in the BM,

transcription factors (Bcl-6, Pax-5, Blimp-1, XBP-1, IRF-4, NF-Atc, octamer binding proteins, and others) regulated by environmental signals control peripheral B-cell development [43].

A subpopulation of B cells called B-1 B cells are found mainly in the peritoneal and pleural body cavities and, like MZBs, form an innate natural antibody defense [14, 33, 44–47]. Although they share many features with traditional (B-2-type) MZBs, B-1 cells likely arise from a separate developmental pathway (Fig. 14.1 [48–50]). In humans, B-1a B cells were considered a precursor of B-chronic lymphocytic leukemia (B-CLL), mainly due to CD5 expression on malignant cells, although recent data suggests a memory B-cell origin [47, 51, 52].

T, NK, NK/T, and Dendritic Cell Development

T-cell development initiates with thymic seeding by BM-derived precursors (Fig. 14.2 [53, 54]). Signaling through the Notch-1 pathway specifies T-lineage fate and blocks B-lineage infidelity [55–59]. Early double-negative (DN1; CD4–/CD8–) GATA3-dependent progenitor cells retain B, T, NK, NK/T, and DC developmental potential [60]. By the DN2 stage, B- and NK-cell potential is lost [20, 61–63]. During the transition to DN3 cells, T-cell receptor (TCR) β , γ , and δ genes begin rearranging and DC potential is lost [20]. DN3 cells combine rearranged TCR β , invariant pre-T α , and specific CD3 complex components into a surface pre-TCR for early (so-called β) selection [64, 65]. Transition to DN4 cells is coupled to a pre-TCR-mediated down regulation in E47 expression [3, 20]. Cycling CD8, immature single-positive (ISP) cells transition to TCR α -rearranging, double-positive (DP; CD4+/CD8+)/ $\alpha\beta$ TCR+ cortical thymocytes [66–69]. DP T cells undergo positive and negative selection, or death by neglect, to form naive CD4 or CD8 single-positive (SP) cells in the thymic medulla [70, 71]. $\alpha\beta$ TCR+, CD4, and CD8 SP T cells emigrate the thymus, recirculate, and take up residence in lymph nodes, Peyer patches, spleen, BM, and other sites. Human T cell development also begins in the thymus and largely resembles mouse T cell maturation (Fig. 14.2 [72–76]).

T-lineage commitment parallels CD25 expression, TCR β , γ , and δ gene rearrangements and the DN1-to-DN2 transition. At this point, developing T cells become either TCR $\gamma\delta$ or TCR $\alpha\beta$ lineage restricted. The mechanism for this choice remains controversial [77–80]. The $\gamma\delta$ T cells have limited TCR V-region gene usage and pass through the thymus in waves to seed mainly epithelial barriers of the gut, skin, and reproductive tract [81]. Human $\gamma\delta$ T cells develop in roughly the same way and emigrate the thymus to seed peripheral epithelial barriers [82].

NK cells develop from early mouse precursor cells and from CD34+ thymic, BM, and umbilical cord blood precursors in humans (Fig. 14.2 [75, 83–87]). They retain germline Ig and TCR gene configurations and are interleukin-15 (IL-15) dependent [88–93]. The IL-15R complex and Id2, Id3, and Ets family transcription factors control early NK-cell development [20, 69, 84, 86, 94–96]. Up to 15% of human peripheral blood lymphocytes are CD56+/CD16+/CD3– NK cells while mouse NK cells lack a CD56 homologue. Both mouse and human NK cells control viral infections and malignancy through a balance of inhibitory and activating receptor stimulation [83, 97, 98]. NK cells are widely dispersed, produce cytokines [IFN- γ , tumor necrotic factor β (TNF- β) IL-10, IL-13 and others] and have cytolytic activity against target cells that are low or deficient in major histocompatibility complex (MHC).

NK/T cells share features and immune regulatory functions that overlap both T and NK cells [99–102]. Their Ets transcription factor–dependent origin from $\alpha\beta$ TCR+, DP T cells, or pre-TCR gene rearrangement precursors is unresolved [96, 103]. Human and mouse NK/T cells are usually DN or CD4 SP, have restricted TCR V gene usage, express NK1.1 (NKR-P1) and CD122 surface proteins, and respond to CD1d MHC elements loaded with glycolipids by secreting IL-4 or IFN- γ [100].

The origin(s) of antigen-presenting DC are unresolved [7]. Some studies indicate that DC arise separately from CLP and CMP [8, 104–112]. The wide tissue distribution and unique patterns of surface protein expression also suggest multiple independent DC origins [9, 113–116]. However, a common DC precursor capable of generating all DC subtypes has been recently shown [10]. Lymphoid DCs function in the thymus and in the periarteriolar lymphoid sheaths (PALSs) of the spleen and lymph nodes, where they present antigens to the innate and adaptive immune system [117–119]. Human DCs develop in similar stages and are also split into myeloid and lymphoid subtypes, although some controversy surrounds the existence of human lymphoid DCs [120–123]. DC neoplasms are rare in humans and a mouse model has not been described thus far.

CLASSIFICATION AND DIAGNOSIS OF LYMPHOID MALIGNANCIES

Despite strong similarities, differences exist in the development of lymphoid cells between humans and mice. For example, IL-7 and its receptor are essential for mouse but not for human early B-cell development [124, 125]. The location of predominant involvement by lymphoid cancers is also different between species. For example, B-cell lymphomas typically develop in the mouse spleen and then disseminate while lymph nodes are the most frequent source for B-cell lymphomas in humans. Not surprisingly, cancers from similar cell types or due to similar genetic insults result in common and distinct features between species. Still, accurate murine models of human lymphoid cancer remain prized for dissecting pathogenetic mechanisms or preclinical testing of tumor targets for efficacy. Schemes for human and mouse lymphoid malignancies that reproducibly classify tumors within and between species are therefore essential.

In 2001 the World Health Organization (WHO) adopted a classification algorithm for human lymphoid tumors [126, 127]. The WHO updates the Revised European-American Classification of Lymphoid Neoplasms (REAL [128]), which is the latest iteration in a series of lymphoid tumor classification schemes [129–131]. Like its 1994 predecessor, the WHO classification divides tumors into lymphoid, histiocytic/dendritic, myeloid, and mast cell categories.

Tumors in each category are further stratified by morphologic, immunophenotypic, genetic, and syndromic features. A cell of origin is postulated for each listed entity. Within the lymphoid category B-cell, T- and/or NK-cell, and Hodgkin lymphoma tumor types are recognized. Criteria for each WHO diagnosis are presented elsewhere [126, 127]. Table 14.1 lists the major lymphoid cell neoplasms of the WHO classification.

In 2002 a subcommittee of the Mouse Models of Human Cancers Consortium (MMHCC) published the “Bethesda classification” of mouse hematopoietic neoplasms based upon a combination of histologic, phenotypic, and molecular features [132, 133]. The Bethesda proposal is built on prior classification schemes, stratifies malignancies according to cell origin, and parallels related human cancers whenever possible [134–136]. The major recognized subgroups include lymphoid and nonlymphoid hematologic malignancies. Criteria for each Bethesda diagnosis are given elsewhere [132]. Table 14.1 lists the major lymphoid malignancies in this classification and “best-fit” comparisons to categories in the WHO classification.

A comprehensive approach is required for accurate lymphoid tumor diagnoses (see Chapter 3). Premortem, mice are observed for behavior changes along with periodic blood cell counts, blood smear, flow cytometric analysis, and, when indicated, clonality determination. At euthanasia, the body is weighed and inspected for cutaneous lesions and subcutaneous lumps. Blood studies include a cell count with differential, blood and BM smears, and potential flow cytometry. The skin is removed to expose superficial lymph node groups and then body cavities opened to collect extravasated fluids that may represent tumor ascites. The spleen is weighed and inspected. Lymphoid tumors infiltrating the white pulp may exhibit a white/gray nodular appearance while those involving the red pulp retain a red/pink smooth consistency. The thymus is also weighed and inspected. Deep lymph node groups are isolated if suspicious. The lungs, liver, kidneys, and brain are removed and examined for tumor infiltration. Thin sliced samples from each organ and the femurs following decalcification are placed in an appropriate fixative (10% neutral buffered formalin, Bouin’s solution) and thin sectioned on a microtome, and slides are stained with hematoxylin and eosin for microscopic evaluation.

Additional studies may be required to determine the presence, type, and spread of malignancy. To perform these procedures, blood and tissues must be properly preserved (see Chapter 3). For immunohistochemistry, tissues can be fixed in 10% neutral buffered formalin or fresh frozen in cold-polymerization OCT (optimal cutting temperature) compound. Blood samples and cell suspensions from organs can be examined with cytospin cell-buttons. Cell suspensions can be evaluated by flow cytometry. DNA, RNA, and protein content are accessible by lysing

cells in specific preservative solutions, such as phenol-saturated guanidinium hydrochloride for RNA analysis.

Determination of T- and B-cell tumor clonality by immunohistochemistry and flow cytometry is standard in humans using antibodies to CD4, CD8, Ig κ , and Ig λ proteins. Here, the normal ratios of CD4-to-CD8 and Ig κ -to-Ig λ expression in mature lymphocytes are close and changes from these ratios will appear in tumors. However, the ratio of Ig κ to Ig λ is roughly 10:1 in mice, and most B-cell tumors remain strongly Ig κ positive, obscuring clonal evolution.

Of particular importance are determinations of IgH, TCR β , and γ gene rearrangements. IgH VDJ rearrangements mark B-lineage cells, while TCR V(D)J rearrangements mark T-lineage cells. T-cell lymphomas can sometimes have IgH D \rightarrow J, but not V \rightarrow DJ, rearrangements and should not be interpreted as mixed T/B-cell tumors. Southern blot hybridization with specific IgJ_H or TCR β probes demonstrate multiple, typically faint rearranged bands in lymphoid hyperplasia or early oligoclonal selection versus distinct, typically intense monoclonal bands in intermediate and advanced stages of leukemia/lymphoma. Polymerase chain reaction (PCR) analysis with primers spanning IgH D \rightarrow J and TCR β or γ D \rightarrow J junctions is also useful for determining oligo- or monoclonal lymphocyte expansions and malignancies. For human B-cell lesions, evidence of somatic hypermutation (SHM) in the Ig locus and in selected non-Ig genes indicates a tumor origin from GC B cells or beyond, although SHM in the absence of GC has been documented [137–139]. While the rate of SHM in mice is about 10-fold less than in human B cells, such determinations can be informative [140].

Cytogenetic studies of human tumors use metaphase-frozen chromosome spreads to determine ploidy, translocations, and deletions. These studies are difficult with mouse chromosomes, which are acrocentric and very similar in overall size. A partial solution is spectral karyotyping (SKY), which combines fluorescence in situ hybridization (FISH) with spectral image analysis [141–144]. Mouse SKY employs 21 distinctly colored chromosome “paints” that color each chromosome uniquely (19 autosomes plus X and Y), facilitating detection of large interchromosomal rearrangements, such as translocations. For smaller lesions, such as gene amplifications or deletions, array-based comparative genomic hybridization (array CGH) provides a potential detection method [145–148].

A powerful method for diagnosing, classifying, and predicting outcomes of human lymphoid malignancies is DNA microarray analysis [149–151]. This technique accurately replicates the traditional classification of acute lymphoblastic versus acute myeloid leukemias [152]. Expression profiling and gene cluster analysis also subclassifies diffuse large B-cell lymphoma (DLBCL) into aggressive,

Table 14.1. (continued)

Type	2001 WHO Classification (Human)	2002 Bethesda Classification (Mice)
Mature T/NK cells	—	Small T-cell lymphoma (STL)
	T-cell prolymphocytic leukemia	
	T-cell large granular lymphocytic leukemia	
	—	T natural killer cell lymphoma (TNKL)
	Aggressive NK-cell leukemia	
	Adult T-cell leukemia/lymphoma	
	Extranodal NK/T-cell lymphoma, nasal	
	Enteropathy-type T-cell lymphoma	
	Hepatosplenic T-cell lymphoma	
	Subcutaneous panniculitis-like T-cell lymphoma	
	Mycosis fungoides	
	Sezary syndrome	
	Primary cutaneous anaplastic large-cell lymphoma	
	Peripheral T-cell lymphoma, unspecified	
	Angioimmunoblastic T-cell lymphoma	
Anaplastic large-cell lymphoma	Large-cell anaplastic lymphoma (TLCA)	

poor outcome (activated DLBCL) versus prolonged survival (GC-derived DLBCL) subtypes [153, 154]. An independent subclassification of DLBCL showed that specific pathway alterations, in addition to cell-of-origin grouping, provide reliable diagnosis and outcome predictions [155]. Expression profiling may also precipitate mergers of seemingly disparate diseases into unified entities. For example, B-CLL exhibits two types of behaviors that segregate with the presence or absence of Ig locus SHM [156, 157]. Tumors lacking SHM predict an aggressive, rapidly fatal course while those with SHM result in less aggressive disease. This correlation suggests that B-CLL arises from two types of mature B cells that differ in having or lacking passage through the GC, as indicated by the SHM status [157–163]. However, studies now show that both B-CLL subtypes have highly similar gene expression profiles and likely originate from memory B cells [51, 52].

Microarray analysis of over 90 mouse lymphoid tumors and cell lines yields molecular groupings consistent with groupings using traditional classification criteria [164]. A “lymphochip” containing target DNA sequences implicated in lymphoid malignancies is useful for screening human samples and is in development for mice [165]. Future gene expression profile comparisons between mouse and human lymphoid malignancies will help determine the extent to which a mouse tumor resembles a comparable human lymphoid malignancy [166].

MOUSE MODELS OF LYMPHOID CELL NEOPLASMS

Many methods exist for discovering candidate tumorigenic genes in mice, including ethylnitrosourea and

gene trap mutagenesis, cre-lox-mediated inversions and deletions, and proviral insertion mutagenesis [167–175]. Genes identified by these and other approaches and known tumor-promoting genes in humans form the group of genes that are studied in mouse models of cancer. Somatic cell gene transfer and reconstitution and transgenic and gene “knockin” (KI) and “knockout” (KO) are the technologies most frequently employed (see Chapters 5–7). Some models are made to mimic a human lymphoid cancer while others develop unexpected lymphoid tumors. Each model, intended or not, has value for dissecting lymphomagenic mechanisms. However, no standardized evaluation scheme for mouse tumors exists, unlike the situation in human surgical pathology. This may cause uncertainty in the classification of certain modeled malignancies.

PREMALIGNANT LYMPHADENOPATHIES AND LYMPHOID CELL EXPANSIONS

Increased numbers of lymphoid cells are caused by homeostatic disorders that fail to properly regulate cell proliferation and/or death. Increases in proliferation may be so great that they mask concomitant increases in cell death, as may be seen in *c-MYC* overexpression [176, 177]. However, too many cells do not constitute a lymphoid cancer. Additional fundamental cell changes must occur, including independence from growth signals, insensitivity to antigrowth signals, blockade of apoptosis, and immortalization [178]. During immortalization, human cells overcome both replicative senescence and cellular crisis by disabling the *p53* and *Rb* tumor suppressor pathways and

activating telomerase [179, 180]. In contrast, many mouse cells are immortalized by repression of the *p19^{ARF}-p53* signaling pathway alone [181]. Clearly, human and mouse cells have fundamental differences on the road to cancer.

FAS AND FAS LIGAND

The *lpr* (lymphoproliferation) or *gld* (generalized lymphoproliferative disease) mice have mutant *Fas* (*CD95/Apo1*) or *FasL* (*CD95L*) genes and signaling defects [182, 183]. The *gld* mice develop polyclonal expansions of DN T cells and altered B-cell subsets with generalized lymphadenopathy and a lupuslike autoimmune disease due to decreased cell death [184]. A similar pathology occurs in humans with *Fas/FasL* mutations in the autoimmune lymphoproliferative syndrome (ALPS), also known as Canale–Smith syndrome [185].

In general, mouse models with a single gene alteration experience a lag to cancer formation until companion mutations required for transformation occur. Strain-specific modifying factors or crosses between complementary tumor inducers, such as *Pim-1* and *c-Myc*, may decrease this lag time significantly [186]. Also, strain differences strongly influence the tumor type that ultimately occurs [187]. For example, a *c-Myc* transgene in C3H/HeJ mice causes T-cell lymphomas while the same transgene integrated at the same genomic locus causes B-cell lymphomas in C57BL/6 mice [188].

MODELS OF B-CELL CANCER

Mouse genetic models of B-cell cancer may be caused by inappropriately regulated signaling molecules (*Bcr-Abl*, *Blk*, *Pim1*, *Fas*, and *FasL*), transcription factors (*c-Myc*, *TEL/AML1*, *Aiolos*, *HOX11*), tumor suppressors (*p53*, *p16^{INK4a}/p19^{ARF}*, *Bcl-2*), cytokines (*IL-6*, *IL-7*), and adapter molecules (*TCL1*) (Fig. 14.3). These examples form one or more B-cell tumor type as defined in the MMHCC classification and discussed in sections under their tumor-type headings.

Precursor B-Cell Lymphoblastic Lymphoma/Leukemia (pre-B-LBL)

Pre-B-LBL form sheets of medium-sized blast cells with distinct histologic features [132]. These tumors are high grade and have numerous mitoses and apoptotic cells. Pre-B-LBL arise from BM precursors and have a sIg⁻/B220⁺/CD19⁺/TdT⁺ immunophenotype. They contain IgH but not IgL rearrangements and may present with splenomegaly and/or lymphadenopathy. Mature B-LBL show the same general features as pre-B-LBL but lack TdT expression and are sIg⁺ with IgH and IgL rearrangements. The human counterpart malignancies are

pro-B and pre-B acute lymphoblastic leukemia (B-ALL) or B lymphoblastic lymphoma (B-LBL).

Philadelphia Chromosome (*Bcr-Abl*). The Philadelphia chromosome (Ph) originates from a reciprocal translocation between chromosomes 9 and 22 that results in a short der(22) chromosome [189, 190]. A hallmark of chronic myelogenous leukemia (CML; see Chapter 17), the Ph also occurs in 20% of adults and 5% of children with B-ALL [191]. A characteristic t(9;22)(q34;q11) causes a head-to-tail fusion of the breakpoint cluster region (*BCR*) gene on chromosome 22 with the cellular homologue of the Abelson (*c-ABL*) viral oncogene on chromosome 9, placing fused *BCR-ABL* oncogenes under control of the ubiquitously expressed *BCR* promoter [192]. *BCR-ABL* oncogenes encode functional BCR-ABL fusion oncoproteins with constitutive tyrosine kinase activity [193–196]. These fusion oncoproteins occur in two main isoforms of distinct molecular weights, p190 and p210, based mainly upon differences in the translocation breakpoints in the *BCR* gene [197–199]. The p210 isoform is expressed in >90% of CML cases while p190 and p210 are each expressed in about 50% of adult Ph-positive B-ALL cases [195, 200, 201]. Roughly 90% of Ph-positive B-ALL cases in children express p190, compared to 10% that express p210 [190].

Infection of 5-fluorouracil- (5-FU-) treated mouse BM with a *BCR-ABL^{p210}*-expressing retrovirus followed by reconstitution into lethally irradiated hosts yields clonal B-ALL in DBA/2 strain recipients and T-ALL in C57BL/6 mice (Table 14.2 [202]). Separately, infection of 5-FU-treated BALB/c BM with a *BCR-ABL^{p210}*-expressing retrovirus results in CML, B-ALL, T-lymphoma, and possibly macrophage-derived malignancies in BALB/c recipient mice [203]. In a third study, 5-FU-treated BALB/c BM infected with a *BCR-ABL^{p210}*-expressing retrovirus transferred into BALB/c mice results in CML and B-ALL [204].

Metallothionein 1 (mt) promoter *BCR-ABL^{p190}* transgenic mice develop either CML in blast crisis (see Chapter 17) or B-ALL (Table 14.3 [205, 206]). The mt promoter *BCR-ABL^{p210}* transgenic mice develop B- and T-ALL at equal frequencies with a slower onset than *BCR-ABL^{p190}* mice [207]. Independently, studies with mt promoter *BCR-ABL^{p210}* transgenic mice demonstrate T-ALL [208]. Founder *tec* promoter *BCR-ABL^{p210}* transgenic mice develop T-ALL (and possibly B-ALL) while transgenic progeny develop myeloproliferative disorders resembling CML [209]. IgV_H promoter–Eμ or retroviral long terminal repeat (LTR) unit–controlled transgenic mice expressing a synthetic BCR-ABL gene created by fusing *bcr* with *v-abl* sequences develop either B-ALL or thymic-based T lymphomas, most of which would likely classify as T-ALL [210]. A tetracycline-inducible system with *BCR-ABL^{p210}* expressed when

• O5

• O6

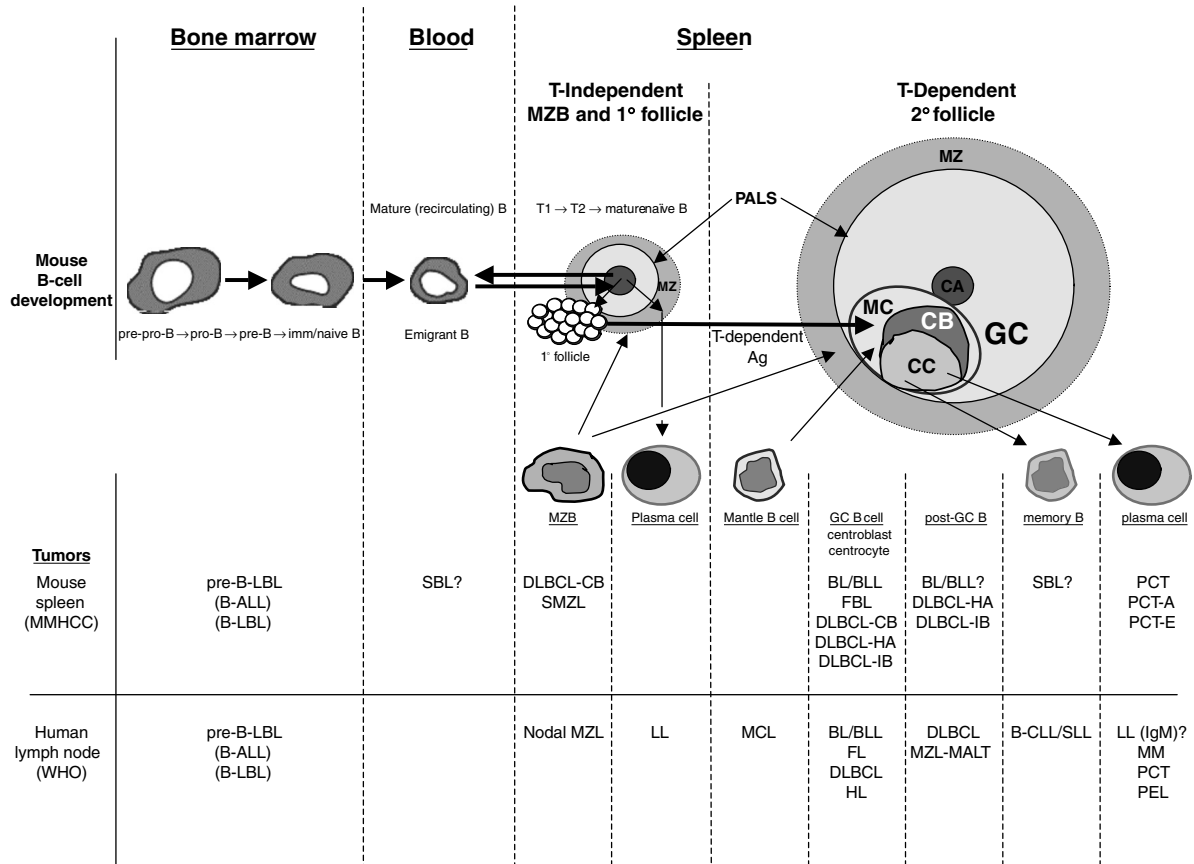

Figure 14.3. Origins of mouse and human B-cell malignancies. Normal mouse B-cell development in BM, blood, and spleen is shown. Below this is a list of tumors that arise from distinct stages of development as described in the MMHCC (Bethesda proposal) classification for mice [132] and the WHO classification for humans [126, 127]. B-cell tumors in the WHO classification that lack a presumed cell of origin are not included. The origin of B-CLL/SLL is from Refs. 47, 51, and 52. CA, central arteriole; CB, centroblasts; CC, centrocytes; FL, follicular lymphoma; GC, germinal center; HL, Hodgkin lymphoma; LL, lymphoblastic lymphoma; MC, mantle cell zone; MCL, mantle cell lymphoma; MM, multiple myeloma; MZ, marginal zone; PALS, periarteriolar lymphoid sheath; PEL, primary effusion lymphoma.

Table 14.2. Gene Transfer and Bone Marrow Reconstitution Models Developing Lymphoma/Leukemia

Cancer	Construct	Host Strain	MMHCC Classification	References
CML	MPZen(<i>bcr-abl</i>)	DBA/2	Pre-B-LBL	202
CML	MPZen(<i>bcr-abl</i>)	C57BL/6	Pre-T-LBL	202
CML	pGD210 (<i>bcr-abl</i>)	BALB/c	Pre-B-LBL, pre-T-LBL	203
CML	JW-RX (<i>bcr-abl</i>)	BALB/c	Pre-B-LBL	204
B-ALL	MING-TEL/AML1	C57BL/6	Pre-B-LBL, pre-T-LBL	223

tetracycline is removed from the drinking water (*tet* off; see Chapter 5) evaluates if continuous transgene expression is necessary for malignancy [211]. Maintenance of *BCR-ABL*^{p210} transgenic mice on tetracycline silences transgene expression. Removal of tetracycline causes the induction of B-ALL that is reversed by

adding tetracycline to resuppress *BCR-ABL*^{p210} expression. Insertion of *BCR-ABL*^{p190} in-frame into exon 1 of the endogenous *bcr* locus by homologous recombination establishes an expression system that is controlled by the endogenous mouse *bcr* regulatory elements, mimicking half of the reciprocal translocation seen in Ph-positive

Table 14.3. Transgenic Mice Developing Lymphoma/Leukemia

Cancer	Transgene	MMHCC Classification	References
B-ALL, CML	mt- <i>BCR-ABL</i> ^{p190}	Pre-B-LBL	205
CML	mt- <i>BCR-ABL</i> ^{p210}	Pre-B-LBL, pre-T-LBL	207
CML	mt- <i>BCR-ABL</i> ^{p210}	Pre-T-LBL	208
CML	tec- <i>BCR-ABL</i> ^{p210}	Pre-T-LBL	209
CML	tTA- <i>BCR-ABL</i> ^{p210}	Pre-B-LBL	211
nm	E μ V _H (<i>bcr-v-abl</i>)	Pre-B-LBL, pre-T-LBL	210
nm	LTR(<i>bcr-v-abl</i>)	Pre-T-LBL	210
BL	E μ - <i>myc</i>	Pre-B-LBL	216
nm	H-2K- <i>blk</i> (Y495F)	Pre-B-LBL, pre-T-LBL	215
nm	E μ P μ -IL-7	(B, $\gamma\delta$ TCR lymphomas)	240
nm	E α -IL-7	Pre-B-LBL	241
T-PLL/T-CLL	E μ - <i>TCL1</i>	SBL	250
T-ALL	pGEMHOX11	SMZL	255
nm	E μ - <i>Pim-1</i>	FBL, DLBCL, pre-T-LBL	217, 263, 264
T-PLL/T-CLL	PE μ -B29- <i>TCL1</i>	FBL, BLL, DLBCL	140
BL	Myc-E λ - <i>c-MYC</i>	T1/T2 B lymphoma	275
BL	Ig/Myc (YAC)	T1/T2 B lymphoma	277, 278
PCT, MM	H2-L ^d - <i>IL-6</i>	PCT-E, PCT-A	291
nm	SV40-E μ - <i>v-abl</i>	PCT-E, PCT-A	292
FL	SV40-E μ - <i>bcl-2</i>	PCT, pre-B-LBL	293
T-ALL	Lck(prox)- <i>Tal1</i>	Pre-T-LBL	332
T-ALL	Lck(prox)- <i>Tal1</i> (R188/9G)	Pre-T-LBL	333
T-ALL	mt- <i>Rbm2</i>	Pre-T-LBL	326, 327
T-PLL/T-CLL	plck- <i>TCL1</i>	STL	368
T-PLL/T-CLL	CD2- <i>p13</i> (<i>MTCP1</i>)	STL	369
nm	H-2D ^d - <i>IL-15</i>	TNKL	375
nm	pRc/CMV-HMGI-C/T	TNKL	376

Table 14.4. Knockin and Knockout Mice Developing Lymphoma/Leukemia

Cancer	Construct	Locus	MMHCC Classification	References
B-ALL	<i>BCR-ABL</i> ^{p190}	<i>bcr</i> KI	Pre-B-LBL	212
B/T-ALL, NHL	<i>p16</i> ^{INK4a} / <i>p19</i> ^{ARF}	KO	Pre-B-LBL	235
nm	<i>Aiolos</i>	KO	Pre-B-LBL	230
Many types	<i>p53</i>	KO	SMZL, pre-T-LBL	260
Leukemias	<i>Msh2</i>	KO	Pre-T-LBL	347
Many types	<i>Atm</i>	KO	Pre-T-LBL	301–303
Many types	<i>Pten</i>	(+/-)	Pre-T-LBL	342, 343
nm	<i>Ku70</i>	KO	Pre-T-LBL	356, 357
Breast/ovarian	<i>Brca2</i>	KO	Pre-T-LBL	360
nm	<i>E2a</i>	KO	Pre-T-LBL	308
Many types	<i>p53</i>	KO	Pre-T-LBL	334, 335
B/T-ALL, CML	<i>Ikaros</i>	KO	Pre-T-LBL	311

cases (see Chapter 5 [212]). These *BCR-ABL*^{p190} KI mice develop pre-B-ALL (Table 14.4). In sum, mice containing *BCR-ABL*-infected BM or expressing either form of *BCR-ABL* (or *bcr-v-abl*) using transgenic, tetracycline-inducible or KI technologies develop mainly B- or T-ALL with variable penetrance and strain dependence [213]. The

p210 isoform of *BCR-ABL* generally does not result in B-ALL in humans.

Blk. Blk is a Src family tyrosine kinase that associates with and signals from the pre-BCR and BCR during

development [214]. Mice with a constitutively active Blk (Y495F) cDNA flanked by a H-2K promoter and E μ develop pro-B- and pre-B-LBL, along with ISP-stage thymic pre-T-LBL (Table 14.3 [215]). B-lineage tumors occur in 45% of mice by six months. Activating lesions for the *Blk* homologue in human B- and T-cell tumors have not yet been described.

c-Myc. Pre-B-LBL arise in C57BL/6 \times SJL mice with an integrated murine retroviral E μ LTR-*myc* transgene (Table 14.3 [186, 216]). Most tumors lack IgL gene rearrangements and are sIg $^-$. Crossing E μ LTR-*myc* with E μ -*pim-1* transgenic mice, which develop low-frequency pre-T-LBL, results in congenital pre-B-ALL/LBL [186, 217]. E μ dysregulation of *c-Myc* does not appear to cause Burkitt lymphoma (BL), as in humans with IgH- or IgL-to-*c-MYC* gene rearrangements [218, 219].

TEL/AML1. A t(12;21)(p13;q22) occurs in 25% of pediatric and 3% of adult B-ALL cases, resulting in a *TEL/AML1* oncogene [220–222]. *TEL/AML1* retains the amino portion of the TEL protein fused to the AML1 DNA binding domain. *TEL/AML1* may cause B-ALL by direct repression of *AML1* target genes or by TEL inhibition of other ETS family proteins via binding through its pointed domain [223–225]. Transduction of wild-type or *p16^{Ink4a}/p19^{Arf}*-null BM with a murine stem cell LTR-*TEL/AML1* retrovirus was followed by adoptive transfer into lethally irradiated C57BL/6 mice [223]. A low frequency of pre-B-ALL and T-ALL from the transduced wild-type donor cells and a higher frequency of an undetermined leukemia type from the *p16^{Ink4a}/p19^{Arf}*-deficient cells is seen (Table 14.2 [223]).

Aiolos. *Ikaros*, *Aiolos*, *Helios*, *Eos*, *Pegasus*, and *Daedalus* are members of a kruppel-like zinc finger transcription factor family that binds DNA and regulates B- and T-cell development and function [226–229]. Targeted inactivation of *Aiolos* results in hyperproliferation and constitutive B-cell activation followed by lymphadenopathy and evolution into probable B-LBL in 20% of mice (Table 14.4 [230]). Alternatively, spliced *Aiolos* isoforms lacking a full complement of DNA binding domains in normal and leukemic human B cells have been reported, but their role in B-cell transformation is not resolved [227, 231].

p16(Ink4a)/p19(Arf). The overlapping *p16^{Ink4a}-p19(p14)^{ARF}* genes encode tumor suppressor proteins that inhibit cancer formation [232]. Loss of *p16^{Ink4a}*, a cyclin-dependent kinase inhibitor, increases cell cycling by increased Rb phosphorylation while loss of mouse *p19^{Arf}* (or human *p14^{ARF}*) increases Mdm2-mediated ubiquitination of *p53*, leading to decreased *p53* activity [233,

234]. Mice deficient in *p16^{Ink4a}/p19^{Arf}* develop mainly soft-tissue sarcomas or mitotically active B220+ B-cell lymphomas with prominent nucleoli that efface lymph nodes [235]. Although not further characterized, these features suggest a B-LBL phenotype (Table 14.4). Deletion of *p16^{Ink4a}/p14^{ARF}* occurs in 20% of B-ALL and 60% of T-ALL arising during childhood [236]. Also, DNA methylation of the *p16^{Ink4a}* (but not the *p14^{ARF}*) locus occurs in multiple types of non-Hodgkin lymphoma (NHL) and acute myeloid leukemia (AML) accompanied by loss of *p16^{Ink4a}* expression [237].

IL-7. IL-7 and the IL-7/ γ cR regulate B and T lymphopoiesis (Figs. 14.1 and 14.2 [238]). Four distinct transgenic strains aberrantly express IL-7 [239–242]. An IgH promoter–E μ –IL-7 transgene causes thymic enlargement, B- and T-cell proliferations with adenopathy, skin-homing T-cell infiltrates, and B- and T-cell lymphomas in 100% of animals by 4.5 months (Table 14.3 [240]). Clonal B220+/sIgM+ B-cell and DN/Thy1+/ $\gamma\delta$ TCR+ T-cell lymphomas are observed but not further characterized. Separately, a MHC-II E α promoter–IL-7 transgene causes λ 5 and EBF-expressing pre-pro-B/pro-B lymphoid tumors with germline Ig genes [241]. Clonality is difficult to establish and femurs are packed with lymphoid blast cells accompanying lymphadenopathy. The tumor incidence varies by strain, with almost 100% of BALB/c and 25% of C57BL/6 mice developing morbid disease. Isolated clones develop into macrophages in culture, consistent with a bipotential B-cell/macrophage stage in early BM and fetal lymphocyte development [243, 244]. Human lymphoid malignancies from IL-7 dysregulation have not been reported.

Small B-cell leukemia/lymphoma (SBL)

SBL occurs in old mice of different strains and appears as small round cells with scant cytoplasm, condensed chromatin, and a mature sIg+/B220+/CD19+ immunophenotype [132]. Mitoses and apoptotic cells are rare. IgH and IgL genes are rearranged and tumors show monoclonal banding patterns. CD5, a discriminating surface molecule for B-CLL/SLL and mantle cell lymphomas (MCLs) in humans, is less useful for classifying mouse B-cell tumors, including SBL, since 85% of all mouse B-cell tumors express CD5 [127, 164]. SBL usually originates from the spleen or lymph nodes and may spill over into the blood, forming a leukemic phase, which contrasts with human B-CLL/SLL, which usually begins with a leukemic phase.

TCL1. Dysregulated *TCL1* expression causes mature, chronic T-cell malignancies in humans [245, 246]. The tumorigenic mechanism likely depends on augmented AKT (protein kinase B) activity leading to increased cell

survival and proliferation [247–249]. Mice with a IgV_H promoter- $E\mu$ -*TCL1* transgene develop sIgM+/CD5+/Mac-1(CD11b)+ small-cell leukemias originating as peritoneal expansions [250]. B cells then spread to the spleen and BM before entering a leukemic phase with monoclonality at 13–18 months of age (Table 14.3). Splens are infiltrated and marginal zones expanded by cells without surface antigen expression typical of MZB. The peritoneal origin and surface antigen expression pattern suggests possible transformation of a B-1a B-cell precursor [33, 251].

Splenic Marginal Zone Lymphoma (SMZL)

SMZL is common in nonmanipulated NFS.V+, AKXD R1, and NZB strains and demonstrates a sIgM+/B220+/CD19+ mature B-cell immunophenotype with clonal IgH and IgL rearrangements [164]. Splenomegaly is typical while involvement beyond regional lymph nodes is uncommon. SMZLs start as low-grade tumors of MZB and are made of medium-sized cells with abundant pale cytoplasm and few mitoses. A thin marginal zone initially expands, which may be followed by invasion of both red and white pulp and conversion to an aggressive lesion with centroblastic morphology and increased mitoses [252]. Human splenic marginal zone lesions are mainly from infiltration by tumors of nearby mantle and follicular cell origin. The major human counterpart lesion could be a nodal MZL [127]. Human MZL of mucosa-associated lymphoid tissue (MALT) type, which initiates in the GI tract from chronic *Helicobacter pylori* infection, is likely a post-GC B-cell malignancy [127]. In mice, polyclonal *H. pylori*-associated MALT accumulations have been reported [253].

HOX11. Human T-ALL exhibit t(10;14)(q24;q11), which moves the *HOX11* homeodomain-containing transcription factor coding sequence near *TCR* α/δ regulatory regions resulting in ectopic expression of *HOX11* in thymocytes [254]. About 20% of CD-1 strain mice with an IgH promoter- $E\mu$ -*HOX11* transgene develop splenic marginal zone hyperplasia, followed at 10–20 months by 85% of mice developing an IgM+/IgD+ SMZL (Table 14.3 [255, 256]). Transformation of MZB is suggested, although T2 and B1 B cells are IgM/IgD positive and locate in the marginal zone of mice. An association between *HOX11* expression and B-cell cancers in humans has not yet been reported.

p53. The *p53* tumor suppressor actively inhibits cell cycle progression until DNA damage has been repaired [257, 258]. *p53* is the most frequently mutated gene in humans and promotes multiple types of malignancy in KO mice [259]. Male (C57BL/6 \times 129) strain, *p53* KO mice develop B220+/CD5+/IgM+ SMZL and thymic pre-T-LBL by 12 weeks (Table 14.4 [187, 260]).

Follicular B-Cell Lymphoma (FBL)

FBL is the most common sIgM+/B220+/CD19+ mature B-cell lymphoma in many mouse strains. Irregularly shaped, diffuse white pulp expansions from enlarging follicles begin in the spleen, lymph nodes, or Peyer patches, resulting in organomegaly. FBL originates from GC B cells and contains large (centroblasts, immunoblasts), small (centrocytes), or a mixture of large and small tumor cells with scant cytoplasm and smooth or cleaved nuclei with or without prominent nucleoli, respectively. Tumor cells are clonal for IgH and IgL rearrangements and mitotic activity parallels the number of centroblasts present. FBLs are typically low-grade lesions resembling human follicular lymphomas. Unlike human follicular lymphomas, mouse FBL is not associated with *Bcl-2* gene rearrangement [132].

Pim1

Pim1 was originally identified as a candidate mouse T-cell lymphomagenic gene by proviral insertion [261]. It encodes a serine/threonine kinase of unknown function [262]. LTR- $E\mu$ -*Pim-1* transgenic mice develop pre-T-LBL between 7 and 10 months (Table 14.3 [217, 263]). The rate of tumor formation is accelerated to 7–8 weeks by Moloney murine leukemia virus (MuLV) insertions that activate *c-myc* and *N-myc* proto-oncogenes. Animals not developing pre-T-LBL by 10 months develop FBL with mixed centroblast and centrocyte populations, a variable mitotic rate, and usual involvement of mesenteric lymph nodes [263, 264]. They also develop DLBCL, probably multiple subtypes [263]. Human *Pim1* shows point mutations caused by aberrant SHM in most DLBCL but not in normal GC B cells or follicular lymphomas [265]. A role for *Pim1* SHM in causing DLBCL has not been demonstrated yet.

TCL1. Human *TCL1* is expressed at high levels in mantle zone B cells and reduced levels in GC B cells and is silenced in post-GC memory B and plasma cells [266]. B29 promoter- $E\mu$ -*TCL1* transgenic mice develop multiple types of GC-based B-cell lymphoma, including Burkittlike lymphoma (BLL), FBL, and DLBCL [140]. One analyzed FBL is Bcl-6+/TdT- and demonstrates SHM of IgJ_H. Many human B-cell lymphomas, including FL, BL, and DLBCL express abundant *TCL1*, suggesting a role for *TCL1* overexpression in these tumors [266–270].

Burkitt and Burkittlike Lymphoma (BL, BLL)

BL is a sIgM+/B220+/CD19+, high-grade lesion that appears as sheets of lymphoblasts with abundant mitoses

and a “starry sky” diffusely infiltrative pattern from ingestion of apoptotic debris by macrophages. Hematopoietic (spleen, lymph nodes, sometimes thymus) and non-hematopoietic organs are involved. A GC or post-GC B-cell origin is postulated. The main difference between BL and pre-B-LBL/B-LBL is the lack of TdT and presence of *c-Myc* activation by translocation or other means in BL. BLL, also called lymphoblastic lymphoma (LL) or DLBCL-LL, is phenotypically similar to BL with fewer mitotic and apoptotic cells. It is histologically identical to pre-B-LBL and pre-T-LBL and is distinguished by sIg expression [132]. BLL lacks functional *c-Myc* activation and often has a leukemic phase. Some inbred mouse strains develop BLL with age.

***c-Myc*.** Human BL is associated with infection by the Epstein–Barr virus (EBV) and translocations of the *c-MYC* locus at 8q24.12 with 14q32 (IgH), 2p12 (Igκ), or 22q11.2 (Igλ) loci, causing aberrant *c-MYC* expression [219, 271–274]. BL does not occur spontaneously in mice. Eμ LTR-*myc* transgenic mice develop pre-B-LBL and not BL [186, 216]. *c-Myc* promoter–Eλ–*c-Myc* transgenic mice develop tumors that histologically resemble human BL but continue to express pre-B-cell antigens and lack SHM and Bcl-6 expression, both signatures of a GC-B cell experience (Table 14.3 [164, 275]). Crossing this λ-MYC mouse with a *Bcl-6*–/– mouse that lacks GC formation does not alter the kinetics of tumor development, confirming that this mouse is not a model of human BL [164, 276]. Inserting *c-MYC* into the IgH locus on a yeast artificial chromosome (YAC) vector followed by generation of transgenic mice results in IgM+/IgD+/CD43+ transitional stage B-cell lymphomas and not BL [277, 278]. The inability to model BL in mice by manipulating *c-Myc* may reflect a corequirement for EBV-related factors.

***TCL1*.** Human BLL always demonstrates dysregulated *c-MYC* through *Ig/c-MYC* translocations [127]. B29 promoter–Eμ–*TCL1* transgenic mice develop IgM+/B220+/CD5+ BLL at a high rate between 4 and 12 months and demonstrate IgH SHM and Bcl-6 expression (Table 14.3 [140]).

Diffuse Large B-Cell Lymphoma (DLBCL)

DLBCL is an aggressive mature B-cell malignancy with centroblastic (CB), immunoblastic (IB), histiocyte-associated (HA), and primary mediastinal (PM, thymic) variants in mice [132]. Common to all subtypes is a sIgM+/B220+/CD19+ immunophenotype with clonal IgH and Ig rearrangements. CB, IB, and HA subtypes usually demonstrate splenomegaly or lymphadenopathy while PM shows mainly thymic enlargement. It is

important to note that FBL was originally defined as having small-cell, large-cell, and mixed histologic phenotypes [136]. In the Bethesda classification, the original FBL, large-cell subtype is now considered a DLBCL [132].

DLBCL-CB originates from GC B cells or splenic MZB and must be distinguished from FBL or SMZL with increased centroblasts. Both IB and HA subtypes arise from GC or post-GC B cells while PM derives from thymic B cells. DLBCL-CB is comprised of at least 50% centroblasts that are medium sized with scant cytoplasm, round nuclei, prominent nucleoli, and numerous mitoses. This lesion overruns lymphoid structures, may originate from aggressive transformation of indolent FBL or SMZL, and is similar to human DLBCL, centroblastic variant. DLBCL-IB contains excess immunoblasts that are large with abundant cytoplasm, round nuclei with prominent nucleoli, and a high mitotic rate. A starry sky pattern may be seen with increased apoptotic cells. DLBCL-HA may involve the liver and contains many large histiocytes and foreign body giant cells intermixed with malignant centroblasts and immunoblasts. The pattern of growth is mainly nodular rather than diffuse, and this lesion resembles human histiocyte/T-cell-rich DLBCL [127]. It may be difficult to distinguish DLBCL-HA from histiocytic sarcoma, a tumor common to several mouse strains (see chapter 17 [279]). Lastly, DLBCL-PM demonstrates medium to large tumor cells with prominent nucleoli and abundant mitoses. Involvement begins in the thymic medulla with a diffuse, starry sky pattern of growth. There may not be a human counterpart lesion.

***Pim-1, TCL1, and BM5def virus*.** DLBCL may arise de novo or by aggressive transformation of FBL and possibly SMZL. Ionizing radiation causes an increased frequency of pre-T-LBL, FBL, and DLBCL-CB in Eμ-*Pim-1* transgenic mice (Table 14.3 [164, 263]). DLBCL-HA occurs in older AKXD RI mice and in B29-Eμ-*TCL1* transgenic mice in a mixed (C57BL/6 × C3H) background [140, 280]. Mice coinfecting with a replication-defective (BM5def) and a helper virus develop an immunodeficiency syndrome termed MAIDS• [281, 282]. After a long latency, MAIDS mice develop DLBCL-PM [164].

Plasma Cell Neoplasms

Plasmacytoma (PCT) is a cytIg+/CD43+/CD138+ tumor of medium-sized Ig-secreting plasma cells [132]. PCT appears rarely in spleens and lymph nodes of some older inbred strains and forms at high frequency in mesenteric granulomas induced by pristane mineral oil injection of BALB/c, NZB, or F1 crossed mice [283–285].

Characteristic t(12;15) rearrangements of *c-Myc* and IgH loci promote pristane-induced PCT [286]. Activating *c-MYC* gene rearrangements also occur in 15% of plasma cell–derived human multiple myeloma (MM), although they may be secondary rather than initiating events [287–289]. Extrasosseous PCT (PCT-E) is a mature plasma cell–derived variant that may involve the spleen, lymph nodes, or Peyer patches in nodular or diffuse patterns. Anaplastic PCT (PCT-A) is another variant that contains mixtures of less mature plasmablasts and immunoblasts in diffuse patterns involving the spleen or lymph nodes. These PCTs rarely have translocations involving *c-Myc* (C.-F. Qi and H. Morse, unpublished observations). Importantly, no agreed-upon model for an intramedullary BM-based plasma cell disease mimicking human MM has been reported in mice [290].

IL-6, v-abl, c-Myc, and Bcl-2. BALB/c mice with a H2-L^d-IL-6 transgene develop mainly IgG-secreting PCT-E or rare PCT-A by 18 months of age (Table 14.3 [291]). These PCT-E variants almost always show activating *c-Myc/IgH* rearrangements and may coevolve with FBL or DLBCL. A simian virus 40 (SV40) promoter–E μ –*v-abl* transgene causes clonal IgA or IgG secreting PCT-E with activating *c-Myc* translocations or PCT-A in 60% of C57BL/6 \times SJL mice by one year of age [292]. Crossing these transgenic mice with SV40 promoter–E μ –*c-Myc* mice, which normally develop pre-B-LBL, induces oligoclonal, IgM-secreting PCT of the peritoneum at an accelerated rate. Also, SV40 promoter–E μ –*bcl-2* transgenic mice develop rare PCT with *c-Myc* rearrangements or early pro-B- or pre-B-LBL [293]. Human follicular lymphomas harbor a t(14;18)(q32;q21.3) that brings E μ near the antiapoptotic *BCL-2* coding region, causing its overexpression and increased cell survival [294–298]. SV40 promoter–E μ –*bcl-2* transgenics do not develop FBL, the mouse equivalent of human follicular lymphoma.

Fas or FasL. Early on, *lpr* or *gld* lymphocytes are not immortal or transformed, and they do not grow indefinitely or cause malignancy in adoptively transferred animals. At 6–15 months, up to 60% of BALB/c and 30% of C3H strain *gld* mice contain emerging clonal PCTs that are obscured among a robust DN T-cell expansion [299]. None of the PCTs have *c-Myc* genomic rearrangements, and transplantation of tumor cells into immune-deficient *scid* mice results in PCT.

MODELS OF T- AND NK-CELL MALIGNANCIES

Genetic models of T- and NK-cell cancer may be caused by inappropriately regulated signaling molecules (*Atm*),

transcription factors (*E2A*, *Ikaros*, *Rbtm2*, *Tall1*), tumor suppressors (*p53*, *Pten*), DNA repair proteins (*Msh2*, *Ku70*, *Brca2*), cytokines (*IL-15*), and adapter molecules (*MTCPI1*, *TCL1*) (Fig. 14.4). As with B-cell cancer models, these examples are discussed in sections under their MMHCC tumor-type headings.

Precursor T-Cell Lymphoblastic Leukemia/Lymphoma (pre-T-LBL)

The histologic appearance of pre-T-LBL is similar to that described for pre-B-LBL. The immunophenotype suggests transformation at distinct stages of intrathymic (or late BM) T-cell development, with immature, CD3+, CD4/CD8 DN, CD4/CD8 DP, CD4 or CD8 SP, TCR+, and cytTdT+ staining patterns observed [132]. The TCR β chain gene is rearranged. The human counterpart malignancies are precursor T-cell lymphoblastic lymphoma (T-LBL) and T-cell acute lymphoblastic leukemia (T-ALL).

Atm. The *ATM* gene encodes a phosphatidylinositol 3 kinase (PI3K) family member protein that responds to DNA damage by phosphorylating key substrates involved in DNA repair and/or cell cycle regulation [300]. Targeted deletion of *Atm* results in rapid induction of pre-T-LBL before four months of age in several mouse strains (Table 14.4 [301–303]). *ATM* defects cause increased sensitivity to ionizing radiation or other agents causing DNA damage and appear to promote T-PLL, B-CLL, MCL, breast cancer, and additional malignancies in humans [304–307].

E2A. *E2A*-encoded proteins E12 and E47 control early B-cell development (Fig. 14.1). Targeted deletion of *E2A* in FVB/NJ mice results in blurring of thymic cortical–medullary junctions and increased numbers of T lymphoblasts that transform into mainly CD4/CD8 DP pre-T-LBL between three and nine months of age (Table 14.4 [308]). Most tumors display trisomy 15 and upregulated *c-Myc* proto-oncogene expression. The pattern of *E2A* expression is not altered in human T-ALL, although E47 interactions with aberrantly expressed TAL1 or TAL2 proteins may promote T-ALL by abolishing its normal transcription-regulating activity [309, 310].

Ikaros. Targeted removal of the *Ikaros* DNA-binding domain is embryonic lethal, but hemizygous mice develop thymic-based T-cell lymphoproliferations, followed by clonal DN, CD4 or CD8 SP, TCR+ pre-T-LBL in 100% of animals at three to six months of age (Table 14.4 [311]). Tumors uniformly demonstrate loss of heterozygosity (LOH) of the wild-type *Ikaros* allele. Increased levels of *Ikaros* isoforms lacking DNA binding domains are seen in B-ALL, T-ALL, and CML in blast

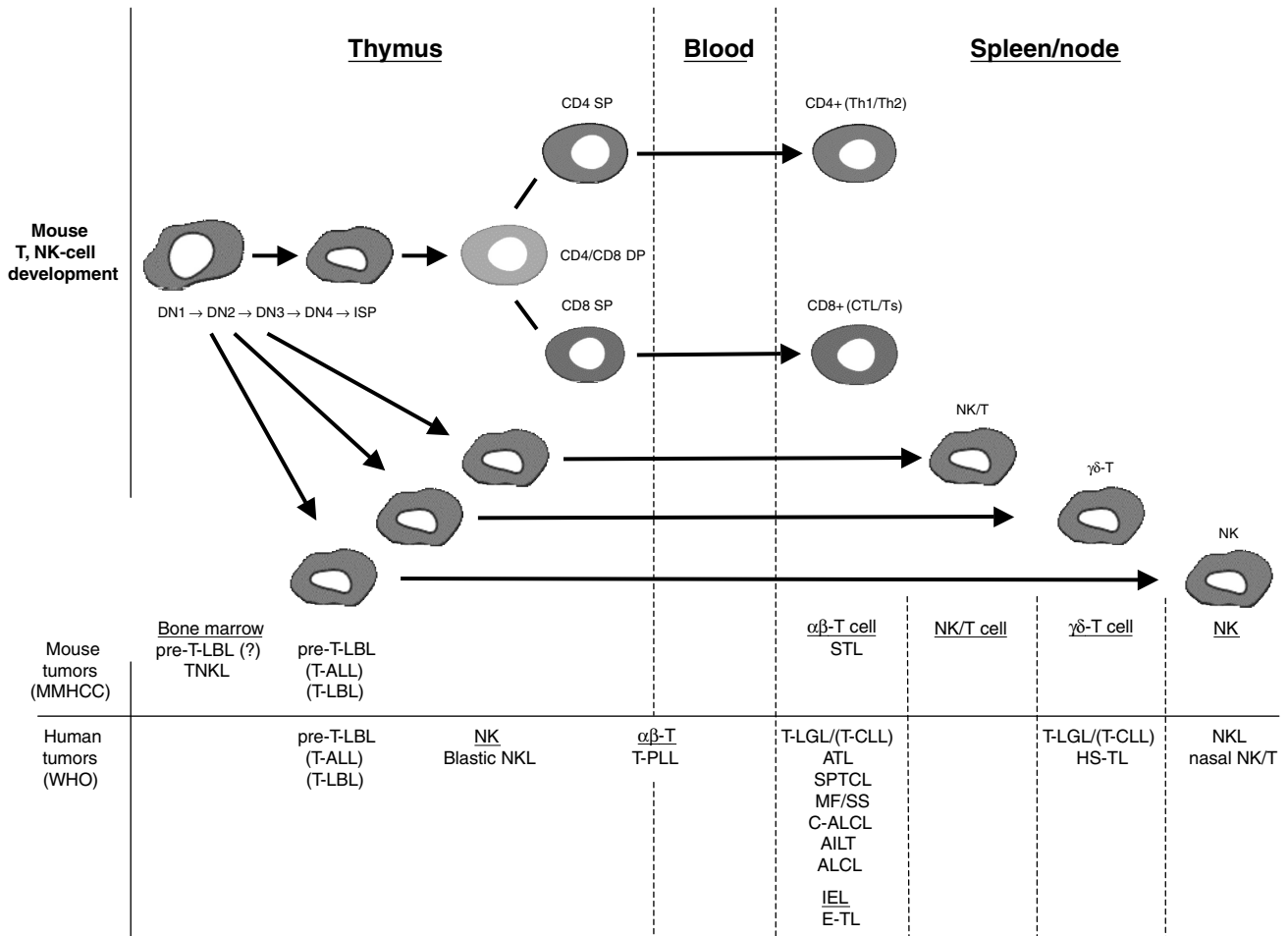

Figure 14.4. Origins of mouse and human T-cell malignancies. Normal mouse T-cell development in BM is shown. Below this is a list of tumors that arise from distinct stages of development as described in the MMHCC (Bethesda proposal) classification for mice [132] and the WHO classification for humans [126, 127]. T-cell tumors in the WHO classification that lack a presumed cell of origin are not included. AILT, angioimmunoblastic T-cell lymphoma; ALCL, anaplastic large-cell lymphoma; ATL, adult T-cell leukemia/lymphoma; C-ALCL, primary cutaneous anaplastic large-cell lymphoma; E-TL, enteropathy-type T-cell lymphoma; HS-TL, hepatosplenic T-cell lymphoma; IEL, intraepithelial lymphocyte; MF/SS, mycosis fungoides/Szary syndrome; NKL; natural killer cell lymphoma; SPTCL, subcutaneous panniculitis-like T-cell lymphoma; T-LGL, T-cell large granular lymphocytic leukemia; T-PLL, T prolymphocytic leukemia.

crisis [312–319]. Overexpression of DNA-binding defective Helios isoforms, another Ikaros transcription factor family member, in T-ALL and HTLV-1-positive adult T-cell leukemia/lymphoma is also observed [320, 321]. The tumorigenic effect of dominant-negative Ikaros family isoforms in mice suggests a potential role for DNA-binding defective Ikaros isoforms in human lymphoid tumors.

Rbtn2. *Rbtn2* (*Lmo2*) encodes a cysteine-rich, tandem LIM domain-containing protein that interacts with a variety of nuclear factors, including Tal1/Sc1, during normal development [322–324]. In humans, t(11;14)(p13;q11)

rearranges the *RBTN2* gene to the TCR δ locus, causing dysregulated expression in T-ALL [322, 325]. About 10% of C57BL/6 \times SJL mice with a mt promoter-*Rbtn2* transgene develop CD4 or CD8 SP, CD4/CD8 DP, and CD4/CD8 DN pre-T-LBL between 1 and 1.5 years (Table 14.3 [326]). Also, 75% of CD2 promoter-*Rbtn2* transgenic mice develop a similar spectrum of $\alpha\beta$ TCR and $\gamma\delta$ TCR pre-T-LBL by 10 months of age [327].

Tal1. *TAL1* (*SCL*) encodes a helix-loop-helix DNA-binding transcription factor and is one of the most common mutation targets in childhood T-ALL [328–330].

t(1;14)(p32;q11), t(1;14)(p34;q11), and deletions aberrantly activate *TAL1* during thymocyte maturation, promoting transformation. Thymocyte-expressing CD2 promoter-*scl* transgenic mice fail to develop T-lineage malignancies unless crossed with *N-ras* transgenic or *p53*-null mice [331]. In contrast, proximal Ick promoter-*Tal1* transgenics develop pre-T-LBL (Table 14.3 [332]). Transgenics lacking the *Tal1* DNA-binding domain still develop CD8 SP pre-T-LBL, suggesting the *Tal1* tumor-promoting effect is likely from interference with additional transacting factors, such as E2A proteins [310, 333].

p53. *p53*-null (C57BL/6 × 129Sv) mice develop lymphoblastic lymphomas originating in the thymus by three or six months, likely representing pre-T-LBL (Table 14.4 [187, 260, 334]). Separately, a *p53* KO model also develops CD4/CD8 DP pre-T-LBL as the main tumor type [335]. Crosses of *p53*-/- mice with a variety of KO or transgenic mouse models (*Rb*+/-, *Msh2*-/-, *Atm*-/-, *Rag1/2*-/-, *MMTV-c-Myc*, *CD2-myc*, *CK2*, and *CD2-scl*) result in oncogenic cooperation with increased rates and/or altered types of lymphoid malignancy [336]. Loss of *p53* occurs in all types of human hematopoietic malignancy at reduced rates compared with rates in solid-tissue tumors [337]. The predisposition for *p53*-null mice developing pre-T-LBL has an unknown etiology.

Pten. PTEN is a tumor suppressor with lipid and protein phosphatase activity that opposes the receptor tyrosine kinase/PI3K-induced activation of AKT [338–341]. Targeted removal of *Pten* is embryonic lethal while *Pten*-heterozygous CD1 strain mice survive and develop thymocyte expansions followed by pre-T-LBL at high frequency (Table 14.4 [342]). Analyzed tumors demonstrate LOH at the wild-type *Pten* locus. Inbred 129Sv and C57BL/6 *Pten*(+/-) strain mice do not develop T-cell leukemia/lymphoma, indicating strain-specific effects contribute to *Pten* tumor suppression [343]. Multiple human tumor types and patients with Cowden disease, Bannayan–Zonana syndrome, and Lhermitte–Duclos syndrome demonstrate diverse types of *PTEN*-inactivating mutations, although *PTEN* is rarely mutated or lost in human lymphoid malignancies [344–346].

Msh2. DNA mismatch repair (MMR) genes maintain fidelity of genomic replication in mammals. Targeted deletion of the *Msh2* MMR gene results in TdT-, Rbtl2-, and Tal1-positive pre-T-LBL that spans the CD4/CD8 DN, CD4 or CD8 SP, and CD4/CD8 DP developmental spectrum (Table 14.4 [347–349]). Human pre-T-LBLs are characterized by aberrant *HOX11*, *RBTN2*, and *TAL1* expression, suggesting a role for defective *MSH2* or additional MMR genes in certain human T lymphomas [350–352].

Ku70. Ku70 protein forms a heterodimeric complex with Ku80 that targets the DNA-PK serine/threonine kinase to sites of double-stranded DNA breaks and V(D)J recombination in B and T cells [353–355]. The majority of *Ku70*-/- mice develop CD4/CD8 DP, pre-T-LBL by eight to nine months of age [356]. Separately, *Ku70* KO mice have significant B-cell defects and develop CD4/CD8 DP, TCRβ-negative pre-T-LBL between two and seven months of age [357]. Preliminary studies indicate 6 of 17 human lymphomas have mutations within *Ku70* core domains responsible for heterodimerization and DNA binding, although a direct role in cancer has not been established [356].

Brca2. *Brca2* promotes homologous recombination but not nonhomologous end-joining pathways of DNA double-stranded break repair [358, 359]. Mice with targeted *Brca2* inactivation show embryonic lethality with incomplete penetrance. Those mice that do survive go on to develop mainly CD4 or CD8 SP pre-T-LBL by 14 weeks of age [360]. Humans carrying *BRCA2* mutations are at increased risk for male and female breast cancer and ovarian cancer, although it is unclear if there is an increased risk for leukemia/lymphoma development [361–364].

Small T-Cell Lymphoma (STL)

The histologic appearance of STL is similar to that described for SBL. STL occurs rarely in inbred strains and shows splenomegaly and lymphadenopathy but not thymic enlargement. The immunophenotype is that of a mature T cell with CD3+, TCR+, CD4, or CD8 SP and cytoTdT-antibody staining. The presumed cell of origin is a recirculating small mature T lymphocyte. Human peripheral T-cell malignancies are usually CD4 or CD8 SP, TCR+ tumors that are subdivided into groups based on genetic, morphologic, and clinical features [127].

MTCPI and TCL1. Human T-cell prolymphocytic leukemia (T-PLL) is usually a malignancy of mature CD4 SP postthymic T cells that may present with splenomegaly, lymphadenopathy, and a leukemic phase [127]. The histology of T-PLL does not exactly resemble that of T-cell chronic lymphocytic leukemia (T-CLL) in humans or STL in mice since the cells are a bit larger with more cytoplasm, coarse chromatin, round to irregular shaped nuclei, and visible nucleoli. Nevertheless, T-PLL demonstrates a prolonged polyclonal premalignant state followed by a clonal mature T-cell malignancy that may take many years to evolve in humans, similar to the prolonged time course in most STL mice. It is typically a malignancy of older individuals or children with the genomic instability syndrome ataxia telangiectasia and exhibits gene rearrangements between TCR regulatory elements and *TCL1* or

MTCP1 proto-oncogenes [365, 366]. *TCL1* and *MTCP1* are grouped in the same gene family by homology and encode small 13–14-kDa proteins that bind and increase AKT serine/threonine kinase activity [248, 367]. *TCL1* transgenic mice generated with the proximal Ick promoter and *MTCP1* transgenic mice made with a CD2 promoter result in polyclonal mature T-cell expansions that evolve into monoclonal CD8 SP T-PLL at 15–20 months of age (Table 14.3 [368, 369]). Both transgenic models show a leukemic phase and diffuse splenic infiltrates along with involvement of nonhematologic tissues such as the liver. These *TCL1* and *MTCP1* transgenic mouse models demonstrate many features resembling human T-PLL and T-CLL and provide evidence for the oncogenicity of gene rearrangements involving these loci in mature T-cell malignancies of humans.

T Natural Killer Cell Lymphoma (TNKL)

TNKL originates in the BM and is composed of large CD3⁺/αβ TCR⁺ tumor cells with variable CD8 and DX5 expression and prominent nucleoli. TNKL grows in a diffusely infiltrative pattern that may involve abdominal viscera, resulting in hepatosplenomegaly and lymphadenopathy [132].

IL-15. An association between chronic inflammation due to infection and the development of cancer has been suggested, such as recurrent *H. pylori* and gastric carcinoma, schistosomiasis, and transitional cell carcinoma of the bladder and hepatitis C virus and hepatocellular carcinoma [370]. A role for inflammation in lymphoid malignancies has also been shown. IL-15 is a proinflammatory and growth-stimulating cytokine that regulates the development, survival, and function of NK cells [88–93]. Regulation of IL-15 expression is mainly posttranscriptional, with multiple checkpoint sequences located in the 5′ untranslated, signal peptide and carboxy-terminal portions of the messenger RNA [371–374]. A transgenic mouse overexpressing secreted IL-15 in multiple tissue types was created by removal of these checkpoint sequences (Table 14.3 [375]). These mice develop early (six to eight weeks) peripheral lymphocytic expansions of DX5⁺/Ly49D⁺/CD3[−] NK and CD8 SP memory T cells followed by dense skin infiltrates, alopecia, and multi-organ lymphocytic infiltrates of clonal, malignant NK/T cells at 12–30 weeks. IL-15 transgenic mice have features in common with human large granular lymphocytic (LGL) leukemia, including extralymphoid tissue involvement, a chronic course that progresses to an aggressive expansion, and a predominance of T-cell subtypes. Furthermore, these mice also exhibit features of human NK/T-cell malignancy, with cutaneous involvement and similar histopathologic findings. Independently, transgenic mice

expressing a truncated form of the HMGI-C protein controlled by a cytomegalovirus (CMV) promoter upregulates IL-2 and IL-15 proteins and their receptors with 35% of mice developing TNKL beginning at one year of age (Table 14.3 [376]). Unlike TNKL, aggressive NK/T tumors in humans probably originate from peripheral NK cells and mainly involve the sinonasal passages [127, 377–379].

CONCLUSIONS

Clearly, mice are not small people. Genes that cause human lymphoid cancers may or may not cause similar tumors in genetically modified mice. Some major categories of human lymphoid cancer have no defined counterpart in mice. For B-cell-derived cancers, these include hairy cell leukemia, lymphoplasmacytic lymphoma/Waldenstrom macroglobulinemia, MCL, extranodal marginal zone lymphoma-MALT type, MM, and Hodgkin lymphoma. For T-, NK-, and NK/T-cell-derived cancers, these include adult T-cell leukemia/lymphoma, mycosis fungoides/Sezary syndrome, and large-cell anaplastic lymphoma. There are no mouse models for DC cancers to date. Also, mice develop lymphoid cancers that may not have a human counterpart. One example is B natural killer cell lymphoma, which occurs in thymectomized (SL/Kh X AKR/Ms) F1 mice [380]. Even minor variations likely reflect differences in lymphoid cell development and transformation mechanisms between species. For example, *TCL1* dysregulation in both human and mouse T cells cause a similar disease (T-PLL/T-CLL vs. STL) with the human lesion almost always CD4 SP and the mouse form always CD8 SP.

Some tumor categories seem preferred and some lacking in mice. There are many genes that generate mouse models of BM-derived pre-B-LBL and pre-T-LBL compared with relatively few genes that create mature B- and T-cell mouse malignancies. Newer techniques, targeting dysregulated gene expression to peripheral lymphoid tissues, promise to somewhat balance this discrepancy. Some genes may also be tumorigenic in one species and not in the other, while some genes in one species may yield distinct tumor types in the other. For example, *c-MYC* promotes BL in humans while it drives pre-B-LBL and PCT in mice. Despite all of these imperfect comparisons, current mouse models and newer improved mouse models will continue to provide insight for transformation of human lymphoid cells into the foreseeable future.

ACKNOWLEDGMENTS

The Teitell laboratory is supported by National Cancer Institute/National Institutes of Health grants CA74929 and

CA90571 and CMISE, a NASA University Research, Engineering and Technology Institute, award number NCC2-1364. M. T. is a scholar of leukemia and lymphoma. We thank Jerrold M. Ward and Herbert C. Morse III for comments and insightful discussions.

REFERENCES

- Morrison SJ, Uchida N, Weissman IL (1995): *Annu Rev Cell Dev Biol* 11, 35–71.
- Busslinger M, Nutt SL, Rolink AG (2000): *Curr Opin Immunol* 12, 151–158.
- Rothenberg EV (2000): *Curr Opin Genet Dev* 10, 370–379.
- Kondo M, Scherer DC, King AG, Manz MG, Weissman IL (2001): *Curr Opin Genet Dev* 11, 520–526.
- Kondo M, Weissman IL, Akashi K (1997): *Cell* 91, 661–672.
- Akashi K, Traver D, Miyamoto T, Weissman IL (2000): *Nature* 404, 193–197.
- Ardavin C, et al. (2001): *Trends Immunol* 22, 691–700.
- Banchereau J, et al. (2000): *Annu Rev Immunol* 18, 767–811.
- Manz MG, Traver D, Miyamoto T, Weissman IL, Akashi K (2001): *Blood* 97, 3333–3341.
- del Hoyo GM, et al. (2002): *Nature* 415, 1043–1047.
- Rolink A, et al. (1995): *Semin Immunol* 7, 155–167.
- Hardy RR, Hayakawa K (2001): *Annu Rev Immunol* 19, 595–621.
- LeBien TW (2000): *Blood* 96, 9–23.
- Dorshkind K, Rawlings DJ (2003): in Hoffman R, Benz EJ, Shattil SJ, Silberstein LE, and McGlave P (Eds), *Hematology: Basic Principles and Practice*. Churchill Livingstone, Philadelphia.
- O’Riordan M, Grosschedl R (2000): *Immunol Rev* 175, 94–103.
- Kee BL, Murre C (2001): *Curr Opin Immunol* 13, 180–185.
- Reya T, Grosschedl R (1998): *Curr Opin Immunol* 10, 158–165.
- Henderson A, Calame K (1998): *Annu Rev Immunol* 16, 163–200.
- DeKoter RP, Singh H (2000): *Science* 288, 1439–1441.
- Quong MW, Romanow WJ, Murre C (2002): *Annu Rev Immunol* 20, 301–322.
- O’Riordan M, Grosschedl R (1999): *Immunity* 11, 21–31.
- Kee BL, Murre C (1998): *J Exp Med* 188, 699–713.
- Nutt SL, Heavey B, Rolink AG, Busslinger M (1999): *Nature* 401, 556–562.
- Rolink AG, Nutt SL, Melchers F, Busslinger M (1999): *Nature* 401, 603–606.
- Max EE (1999): In Paul WE (Ed), *Fundamental Immunology*, 4th ed. Lippincott-Raven, Philadelphia, pp 111–182.
- Batten M, et al. (2000): *J Exp Med* 192, 1453–1466.
- Kurosaki T (1999): *Annu Rev Immunol* 17, 555–592.
- Loder F, et al. (1999): *J Exp Med* 190, 75–89.
- Petro JB, et al. (2002): *J Biol Chem* 277, 48,009–48,019.
- Su TT, Rawlings DJ (2002): *J Immunol* 168, 2101–2110.
- Lu TT, Cyster JG (2002): *Science* 297, 409–412.
- Lo CG, Lu TT, Cyster JG (2003): *J Exp Med* 197, 353–361.
- Martin F, Kearney JF (2001): *Curr Opin Immunol* 13, 195–201.
- Ngo VN, et al. (1999): *J Exp Med* 189, 403–412.
- Hsu BL, Harless SM, Lindsley RC, Hilbert DM, Cancro MP (2002): *J Immunol* 168, 5993–5996.
- Fu YX, Chaplin DD (1999): *Annu Rev Immunol* 17, 399–433.
- Forster R, et al. (1996): *Cell* 87, 1037–1047.
- Martin F, Kearney JF (2002): *Nat Rev Immunol* 2, 323–335.
- Liu YJ, Johnson GD, Gordon J, MacLennan IC (1992): *Immunol Today* 13, 17–21.
- Liu YJ, Zhang J, Lane PJ, Chan EY, MacLennan IC (1991): *Eur J Immunol* 21, 2951–2962.
- Kroese FG, Wubbena AS, Seijen HG, Nieuwenhuis P (1987): *Eur J Immunol* 17, 1069–1072.
- Jacob J, Kelsoe G (1992): *J Exp Med* 176, 679–687.
- Calame KL, Lin KI, Tunyaplin C (2003): *Annu Rev Immunol* 21, 205–230.
- Macpherson AJ, et al. (2000): *Science* 288, 2222–2226.
- Kearney JF, et al. (1997): *Int Rev Immunol* 15, 207–241.
- Kantor AB, Herzenberg LA (1993): *Annu Rev Immunol* 11, 501–538.
- Berland R, Wortis HH (2002): *Annu Rev Immunol* 20, 253–300.
- Hardy RR, Hayakawa K (1991): *Proc Natl Acad Sci USA* 88, 11550–11554.
- Kantor AB, Stall AM, Adams S, Herzenberg LA (1992): *Proc Natl Acad Sci USA* 89, 3320–3324.
- Solvason N, Lehuen A, Kearney JF (1991): *Int Immunol* 3, 543–550.
- Rosenwald A, et al. (2001): *J Exp Med* 194, 1639–1647.
- Klein U, et al. (2001): *J Exp Med* 194, 1625–1638.
- Allman D, et al. (2003): *Nat Immunol* 4, 168–174.
- Montecino-Rodriguez E, Dorshkind K (2003): *Nat Immunol* 4, 100–101.
- Radtke F, et al. (1999): *Immunity* 10, 547–558.
- Guidos CJ (2002): *Semin Immunol* 14, 395–404.
- Ordentlich P, et al. (1998): *Mol Cell Biol* 18, 2230–2239.
- Pear W, et al. (1999): *Cold Spring Harb Symp Quant Biol* 64, 33–38.
- Pui JC, et al. (1999): *Immunity* 11, 299–308.
- Ting CN, Olson MC, Barton KP, Leiden JM (1996): *Nature* 384, 474–478.

61. Benoist C, Mathis D (1999): In Paul WE (Ed), *Fundamental Immunology*, 4th ed. Lippincott-Raven, Philadelphia, pp. 367–409.
62. Engel I, Murre C (2001): *Nat Rev Immunol* 1, 193–199.
63. Engel I, Johns C, Bain G, Rivera RR, Murre C (2001): *J Exp Med* 194, 733–745.
64. Wang B, et al. (1999): *J Immunol* 162, 88–94.
65. Michie AM, Zuniga-Pflucker JC (2002): *Semin Immunol* 14, 311–323.
66. Schilham MW, Moerer P, Cumano A, Clevers HC (1997): *Eur J Immunol* 27, 1292–1295.
67. Okamura RM, et al. (1998): *Immunity* 8, 11–20.
68. Verbeek S, et al. (1995): *Nature* 374, 70–74.
69. Kuo CT, Leiden JM (1999): *Annu Rev Immunol* 17, 149–187.
70. Jameson SC, Bevan MJ (1998): *Curr Opin Immunol* 10, 214–219.
71. Robey E, Fowlkes BJ (1994): *Annu Rev Immunol* 12, 675–705.
72. Blom B, et al. (1999): *Blood* 93, 3033–3043.
73. Blom B, Res PC, Spits H (1998): *Crit Rev Immunol* 18, 371–388.
74. Carrasco YR, Navarro MN, de Yebenes VG, Ramiro AR, Toribio ML (2002): *Semin Immunol* 14, 325–334.
75. Spits H, et al. (1998): *Immunol Rev* 165, 75–86.
76. Spits H (2002): *Nat Rev Immunol* 2, 760–772.
77. MacDonald HR, Radtke F, Wilson A (2001): *Curr Opin Immunol* 13, 219–224.
78. Fehling HJ, Gilfillan S, Ceredig R (1999): *Adv Immunol* 71, 1–76.
79. Kang J, Raulet DH (1997): *Semin Immunol* 9, 171–179.
80. Robey E, Fowlkes BJ (1998): *Curr Opin Immunol* 10, 181–187.
81. Bluestone JA, Khattry R, Sciammas R, Sperling AI (1995): *Annu Rev Cell Dev Biol* 11, 307–353.
82. Plum J, et al. (2000): *Ann N Y Acad Sci* 917, 724–731.
83. Cooper MA, et al. (2001): *Blood* 97, 3146–3151.
84. Williams NS, et al. (1998): *Immunol Rev* 165, 47–61.
85. Raulet DH (1999): *Curr Opin Immunol* 11, 129–134.
86. Ikawa T, Fujimoto S, Kawamoto H, Katsura Y, Yokota Y (2001): *Proc Natl Acad Sci USA* 98, 5164–5169.
87. Carlyle JR, Zuniga-Pflucker JC (1998): *Immunol Rev* 165, 63–74.
88. Bamford RN, et al. (1994): *Proc Natl Acad Sci USA* 91, 4940–4944.
89. Carson WE, et al. (1994): *J Exp Med* 180, 1395–1403.
90. Mrozek E, Anderson P, Caligiuri MA (1996): *Blood* 87, 2632–2640.
91. Carson WE, et al. (1997): *J Clin Invest* 99, 937–943.
92. Kennedy MK, et al. (2000): *J Exp Med* 191, 771–780.
93. Waldmann TA, Tagaya Y (1999): *Annu Rev Immunol* 17, 19–49.
94. Liu CC, Perussia B, Young JD (2000): *Immunol Today* 21, 113–116.
95. Heemskerk MH, et al. (1997): *J Exp Med* 186, 1597–1602.
96. Lacorazza HD, et al. (2002): *Immunity* 17, 437–449.
97. Cerwenka A, Lanier LL (2001): *Nat Rev Immunol* 1, 41–49.
98. Kalberer CP, Siegler U, Wodnar-Filipowicz A (2003): *Blood* 13, 13.
99. MacDonald HR (2002): *Curr Opin Immunol* 14, 250–254.
100. Godfrey DI, Hammond KJ, Poulton LD, Smyth MJ, Baxter AG (2000): *Immunol Today* 21, 573–583.
101. Elewaut D, Kronenberg M (2000): *Semin Immunol* 12, 561–568.
102. Kronenberg M, Gapin L (2002): *Nat Rev Immunol* 2, 557–568.
103. Gapin L, Matsuda JL, Surh CD, Kronenberg M (2001): *Nat Immunol* 2, 971–978.
104. Scheicher C, Mehlig M, Zecher R, Reske K (1992): *J Immunol Methods* 154, 253–264.
105. Inaba K, et al. (1992): *J Exp Med* 176, 1693–1702.
106. Ardavin C, Wu L, Li CL, Shortman K (1993): *Nature* 362, 761–763.
107. Wu L, Li CL, Shortman K (1996): *J Exp Med* 184, 903–911.
108. Vremec D, et al. (1992): *J Exp Med* 176, 47–58.
109. Steinman RM, Pack M, Inaba K (1997): *Adv Exp Med Biol* 417, 1–6.
110. Steinman RM, Pack M, Inaba K (1997): *Immunol Rev* 156, 25–37.
111. Steinman RM, Inaba K (1999): *J Leukoc Biol* 66, 205–208.
112. Saunders D, et al. (1996): *J Exp Med* 184, 2185–2196.
113. Vremec D, Pooley J, Hochrein H, Wu L, Shortman K (2000): *J Immunol* 164, 2978–2986.
114. Shortman K, Caux C (1997): *Stem Cells* 15, 409–419.
115. Ardavin C, Wu L, Ferrero I, Shortman K (1993): *Immunol Lett* 38, 19–25.
116. Henri S, et al. (2001): *J Immunol* 167, 741–748.
117. Leenen PJ, et al. (1998): *J Immunol* 160, 2166–2173.
118. Pulendran B, et al. (1997): *J Immunol* 159, 2222–2231.
119. De Smedt T, et al. (1996): *J Exp Med* 184, 1413–1424.
120. Galy A, Travis M, Cen D, Chen B (1995): *Immunity* 3, 459–473.
121. Hart DN (1997): *Blood* 90, 3245–3287.
122. Bell D, Young JW, Banchereau J (1999): *Adv Immunol* 72, 255–324.
123. Res P, et al. (1996): *Blood* 87, 5196–5206.
124. Peschon JJ, et al. (1994): *J Exp Med* 180, 1955–1960.
125. Puel A, Ziegler SF, Buckley RH, Leonard WJ (1998): *Nat Genet* 20, 394–397.
126. Harris NL, et al. (2000): *Hematol J* 1, 53–66.
127. Jaffe ES, Harris NL, Stein H, Vardiman JW (2001): In Kleihues P, Sobin LH (Eds), *Pathology and Genetics of*

- Tumours of Haematopoietic and Lymphoid Tissues*, World Health Organization Classification of Tumours. IARC Press, Lyon.
128. Harris NL, et al. (1994): *Blood* 84, 1361–1392.
129. Lukes RJ, Collins RD (1974): *Cancer* 34 (Suppl), 1488–1503.
130. Stansfeld AG, et al. (1988): *Lancet* 1, 292–293.
- Q10 131. • (1982): *Cancer* 49, 2112–2135.
132. Morse HC 3rd, et al. (2002): *Blood* 100, 246–258.
133. Kogan SC, et al. (2002): *Blood* 100, 238–245.
134. Fredrickson TN, Hartley JW, Morse HC 3rd, Chattopadhyay SK, Lennert K (1995): *Curr Top Microbiol Immunol* 194, 109–116.
135. Fredrickson TN, et al. (1985): *Am J Pathol* 121, 349–360.
136. Pattengale PK, Taylor CR (1983): *Am J Pathol* 113, 237–265.
137. William J, Euler C, Christensen S, Shlomchik MJ (2002): *Science* 297, 2066–2070.
138. Weller S, et al. (2001): *Proc Natl Acad Sci USA* 98, 1166–1170.
139. Matsumoto M, et al. (1996): *Nature* 382, 462–466.
140. Hoyer KK, et al. (2002): *Proc Natl Acad Sci USA* 99, 14392–14397.
141. Schrock E, Padilla-Nash H (2000): *Semin Hematol* 37, 334–347.
142. Liyanage M, et al. (1996): *Nat Genet* 14, 312–315.
143. Bayani J, Squire JA (2002): *Methods Mol Biol* 204, 85–104.
144. Bayani JM, Squire JA (2002): *Cancer Invest* 20, 373–386.
145. Pinkel D, et al. (1998): *Nat Genet* 20, 207–211.
146. Pollack JR, et al. (1999): *Nat Genet* 23, 41–46.
147. Kashiwagi H, Uchida K (2000): *Hum Cell* 13, 135–141.
148. Lichter P, Joos S, Bentz M, Lampel S (2000): *Semin Hematol* 37, 348–357.
149. Lockhart DJ, et al. (1996): *Nat Biotechnol* 14, 1675–1680.
150. Iyer VR, et al. (1999): *Science* 283, 83–87.
151. Schena M, Shalon D, Davis RW, Brown PO (1995): *Science* 270, 467–470.
152. Golub TR, et al. (1999): *Science* 286, 531–537.
153. Alizadeh AA, Staudt LM (2000): *Curr Opin Immunol* 12, 219–225.
154. Alizadeh AA, et al. (2000): *Nature* 403, 503–511.
155. Shipp MA, et al. (2002): *Nat Med* 8, 68–74.
156. Damle RN, et al. (1999): *Blood* 94, 1840–1847.
157. Hamblin TJ, Davis Z, Gardiner A, Oscier DG, Stevenson FK (1999): *Blood* 94, 1848–1854.
158. Schroeder HW Jr, Dighiero G (1994): *Immunol Today* 15, 288–294.
159. Maloum K, et al. (1995): *Blood* 86, 3883–3890.
160. Cai J, Humphries C, Richardson A, Tucker PW (1992): *J Exp Med* 176, 1073–1081.
161. Fais F, et al. (1998): *J Clin Invest* 102, 1515–1525.
162. Oscier DG, Thompsett A, Zhu D, Stevenson FK (1997): *Blood* 89, 4153–4160.
163. Sakai A, et al. (2000): *Blood* 95, 1413–1419.
164. Morse III HC, Alt FW (Eds) (2003): •
- Q11 165. Alizadeh A, et al. (1999): *Cold Spring Harb Symp Quant Biol* 64, 71–78.
166. Staudt LM, Brown PO (2000): *Annu Rev Immunol* 18, 829–859.
167. Perkins AS (2002): *Funct Integr Genomics* 2, 81–91.
168. Justice MJ (2000): *Nat Rev Genet* 1, 109–115.
169. Schimenti J, Bucan M (1998): *Genome Res* 8, 698–710.
170. Muller U (1999): *Mech Dev* 82, 3–21.
171. Mills AA, Bradley A (2001): *Trends Genet* 17, 331–339.
172. Smith AJ, Xian J, Richardson M, Johnstone KA, Rabbitts PH (2002): *Oncogene* 21, 4521–4529.
173. Rabbitts TH, et al. (2001): *Blood Cells Mol Dis* 27, 249–259.
174. Collins EC, Pannell R, Simpson EM, Forster A, Rabbitts TH (2000): *EMBO Rep* 1, 127–132.
175. Smith AJ, et al. (1995): *Nat Genet* 9, 376–385.
176. Evan GI, et al. (1992): *Cell* 69, 119–128.
177. Askew DS, Ashmun RA, Simmons BC, Cleveland JL (1991): *Oncogene* 6, 1915–1922.
178. Hanahan D, Weinberg RA (2000): *Cell* 100, 57–70.
179. Hahn WC, Weinberg RA (2002): *N Engl J Med* 347, 1593–1603.
180. Hahn WC, Weinberg RA (2002): *Nat Rev Cancer* 2, 331–341.
181. Kamijo T, et al. (1998): *Proc Natl Acad Sci USA* 95, 8292–8297.
182. Matiba B, Mariani SM, Krammer PH (1997): *Semin Immunol* 9, 59–68.
183. Nagata S (1998): *J Hum Genet* 43, 2–8.
184. Davidson WF, Dumont FJ, Bedigian HG, Fowlkes BJ, Morse HC 3rd. (1986): *J Immunol* 136, 4075–4084.
185. Drappa J, Vaishnav AK, Sullivan KE, Chu JL, Elkon KB (1996): *N Engl J Med* 335, 1643–1649.
186. Verbeek S, et al. (1991): *Mol Cell Biol* 11, 1176–1179.
187. Donehower LA, et al. (1995): *Mol Carcinog* 14, 16–22.
188. Yukawa K, et al. (1989): *J Exp Med* 170, 711–726.
189. Sawyers CL (1999): *N Engl J Med* 340, 1330–1340.
190. Laurent E, Talpaz M, Kantarjian H, Kurzrock R (2001): *Cancer Res* 61, 2343–2355.
191. Catovsky D, et al. (1979): *Am J Clin Pathol* 72, 736–745.
192. Heisterkamp N, Stam K, Groffen J, de Klein A, Grosveld G (1985): *Nature* 315, 758–761.
193. Konopka JB, Watanabe SM, Witte ON (1984): *Cell* 37, 1035–1042.
194. Kloetzer W, et al. (1985): *Virology* 140, 230–238.
195. Kurzrock R, et al. (1987): *Nature* 325, 631–635.
196. Lugo TG, Pendergast AM, Muller AJ, Witte ON (1990): *Science* 247, 1079–1082.
197. Griffiths SD, et al. (1992): *Oncogene* 7, 1391–1399.

198. Shtivelman E, Lifshitz B, Gale RP, Canaani E (1985): *Nature* 315, 550–554.
199. Mes-Masson AM, McLaughlin J, Daley GQ, Paskind M, Witte ON (1986): *Proc Natl Acad Sci USA* 83, 9768–9772.
200. Chan LC, et al. (1987): *Nature* 325, 635–637.
201. Hermans A, et al. (1987): *Cell* 51, 33–40.
202. Elefanty AG, Hariharan IK, Cory S (1990): *Embo J* 9, 1069–1078.
203. Daley GQ, Van Etten RA, Baltimore D (1990): *Science* 247, 824–830.
204. Kelliher MA, McLaughlin J, Witte ON, Rosenberg N (1990): *Proc Natl Acad Sci USA* 87, 6649–6653.
205. Heisterkamp N, et al. (1990): *Nature* 344, 251–253.
206. Voncken JW, et al. (1992): *Cancer Res* 52, 4534–4539.
207. Voncken JW, et al. (1995): *Blood* 86, 4603–4611.
208. Honda H, et al. (1995): *Blood* 85, 2853–2861.
209. Honda H, et al. (1998): *Blood* 91, 2067–2075.
210. Hariharan IK, et al. (1989): *Mol Cell Biol* 9, 2798–2805.
211. Huettner CS, Zhang P, Van Etten RA, Tenen DG (2000): *Nat Genet* 24, 57–60.
212. Castellanos A, et al. (1997): *Blood* 90, 2168–2174.
213. Wong S, Witte ON (2001): *Oncogene* 20, 5644–5659.
214. Lowell CA, Soriano P (1996): *Genes Dev* 10, 1845–1857.
215. Malek SN, Dordai DI, Reim J, Dintzis H, Desiderio S (1998): *Proc Natl Acad Sci USA* 95, 7351–7356.
216. Adams JM, et al. (1985): *Nature* 318, 533–538.
217. van Lohuizen M, et al. (1989): *Cell* 56, 673–682.
218. Wright DH (1997): *J Pathol* 182, 125–127.
219. Pelicci PG, Knowles DM, Magrath I, Dalla-Favera R (1986): *Proc Natl Acad Sci USA* 83, 2984–2988.
220. Romana SP, et al. (1995): *Blood* 86, 4263–4269.
221. Romana SP, et al. (1995): *Blood* 85, 3662–3670.
222. Golub TR, et al. (1995): *Proc Natl Acad Sci USA* 92, 4917–4921.
223. Bernardin F, et al. (2002): *Cancer Res* 62, 3904–3908.
224. Fears S, et al. (1997): *Proc Natl Acad Sci USA* 94, 1949–1954.
225. Hiebert SW, et al. (1996): *Mol Cell Biol* 16, 1349–1355.
226. Cortes M, Wong E, Koipally J, Georgopoulos K (1999): *Curr Opin Immunol* 11, 167–171.
227. Schmitt C, et al. (2002): *Apoptosis* 7, 277–284.
228. Westman BJ, Mackay JP, Gell D (2002): *Int J Biochem Cell Biol* 34, 1304–1307.
229. Georgopoulos K (2002): *Nat Rev Immunol* 2, 162–174.
230. Wang JH, et al. (1998): *Immunity* 9, 543–553.
231. Liippo J, et al. (2001): *Eur J Immunol* 31, 3469–3474.
232. Lowe SW, Sherr CJ (2003): *Curr Opin Genet Dev* 13, 77–83.
233. Sanchez-Beato M, Sanchez-Aguilera A, Piris MA (2003): *Blood* 101, 1220–1235.
234. Sharpless NE, DePinho RA (1999): *Curr Opin Genet Dev* 9, 22–30.
235. Serrano M, et al. (1996): *Cell* 85, 27–37.
236. Takeuchi S, et al. (1995): *Blood* 86, 755–760.
237. French SW, et al. (2002): *Clin Immunol* 103, 217–230.
238. Noguchi M, et al. (1993): *Science* 262, 1877–1880.
239. Samaridis J, et al. (1991): *Eur J Immunol* 21, 453–460.
240. Rich BE, Campos-Torres J, Tepper RI, Moreadith RW, Leder P (1993): *J Exp Med* 177, 305–316.
241. Fisher AG, Burdet C, Bunce C, Merckenschlager M, Ceredig R (1995): *Int Immunol* 7, 415–423.
242. Uehira M, et al. (1993): *Int Immunol* 5, 1619–1627.
243. Montecino-Rodriguez E, Leathers H, Dorshkind K (2001): *Nat Immunol* 2, 83–88.
244. Montecino-Rodriguez E, Dorshkind K (2002): *Semin Immunol* 14, 371–376.
245. Teitell MA (2002): In Creighton TE (Ed), *Wiley's Encyclopedia of Molecular Medicine*, Wiley, New York, pp 3106–3108.
246. Pekarsky Y, Hallas C, Croce CM (2001): *Oncogene* 20, 5638–5643.
247. French SW, et al. (2002): *Biochemistry* 41, 6376–6382.
248. Laine J, Kunstle G, Obata T, Sha M, Noguchi M (2000): *Mol Cell* 6, 395–407.
249. Pekarsky Y, et al. (2000): *Proc Natl Acad Sci USA* 97, 3028–3033.
250. Bichi R, et al. (2002): *Proc Natl Acad Sci USA* 99, 6955–6960.
251. Fagarasan S, Watanabe N, Honjo T (2000): *Immunol Rev* 176, 205–215.
252. Fredrickson TN, Lennert K, Chattopadhyay SK, Morse HC 3rd, Hartley JW (1999): *Am J Pathol* 154, 805–812.
253. Enno A, et al. (1995): *Am J Pathol* 147, 217–222.
254. Dube ID, Raimondi SC, Pi D, Kalousek DK (1986): *Blood* 67, 1181–1184.
255. Hough MR, et al. (1998): *Proc Natl Acad Sci USA* 95, 13853–13858.
256. Rosic-Kablar S, Chan K, Reis MD, Dube ID, Hough MR (2000): *Proc Natl Acad Sci USA* 97, 13300–13305.
257. Vogelstein B, Kinzler KW (1992): *Cell* 70, 523–526.
258. Levine AJ, Momand J, Finlay CA (1991): *Nature* 351, 453–456.
259. Parant JM, Lozano G (2003): *Hum Mutat* 21, 321–326.
260. Ward JM, et al. (1999): *Lab Invest* 79, 3–14.
261. Cuyper HT, et al. (1984): *Cell* 37, 141–150.
262. Saris CJ, Domen J, Berns A (1991): *Embo J* 10, 655–664.
263. Repacholi MH, et al. (1997): *Radiat Res* 147, 631–640.
264. Uttridge TD, GebSKI V, Finnie JW, Vernon-Roberts B, Kuchel TR (2002): *Radiat Res* 158, 357–364.
265. Pasqualucci L, et al. (2001): *Nature* 412, 341–346.
266. Said JW, et al. (2001): *Lab Invest* 81, 555–564.
267. Nakayama I, et al. (2000): *Pathol Int* 50, 191–199.
268. Narducci MG, et al. (2000): *Cancer Res* 60, 2095–2100.
269. Takizawa J, et al. (1998): *Jpn J Cancer Res* 89, 712–718.
270. Roos J, et al. (2001): *Pathobiology* 69, 59–66.

271. Lenoir GM, Preud'homme JL, Bernheim A, Berger R (1982): *Nature* 298, 474–476.
272. Kirsch IR, Morton CC, Nakahara K, Leder P (1982): *Science* 216, 301–303.
273. Burkitt DP (1983): *Cancer* 51, 1777–1786.
274. Zech L, Haglund U, Nilsson K, Klein G (1976): *Int J Cancer* 17, 47–56.
275. Kovalchuk AL, et al. (2000): *J Exp Med* 192, 1183–1190.
276. Ye BH, et al. (1997): *Nat Genet* 16, 161–170.
277. Butzler C, Zou X, Popov AV, Bruggemann M (1997): *Oncogene* 14, 1383–1388.
278. Palomo C, Zou X, Nicholson IC, Butzler C, Bruggemann M (1999): *Cancer Res* 59, 5625–5628.
279. Ward JM, Mann PC, Morishima H, Frith CH (1999): In Maronpot RR (Ed), *Pathology of the Mouse: Reference and Atlas*. Cache River Press, Vienna, pp 343–360.
280. Morse HC 3rd, et al. (2001): *Leuk Res* 25, 719–733.
281. Chattopadhyay SK, Morse HC 3rd, Makino M, Ruscetti SK, Hartley JW (1989): *Proc Natl Acad Sci USA* 86, 3862–3866.
282. Aziz DC, Hanna Z, Jolicoeur P (1989): *Nature* 338, 505–508.
283. Morse HC 3rd, Riblet R, Asofsky R, Weigert M (1978): *J Immunol* 121, 1969–1972.
284. Potter M, Wiener F (1992): *Carcinogenesis* 13, 1681–1697.
285. Anderson PN, Potter M (1969): *Nature* 222, 994–995.
286. Shen-Ong GL, Keath EJ, Piccoli SP, Cole MD (1982): *Cell* 31, 443–452.
287. Avet-Loiseau H, et al. (2001): *Blood* 98, 3082–3086.
288. Bergsagel PL, Kuehl WM (2001): *Oncogene* 20, 5611–5622.
289. Shou Y, et al. (2000): *Proc Natl Acad Sci USA* 97, 228–233.
290. Radl J (1981): *Am J Pathol* 105, 91–93.
291. Kovalchuk AL, et al. (2002): *Proc Natl Acad Sci USA* 99, 1509–1514.
292. Rosenbaum H, et al. (1990): *Embo J* 9, 897–905.
293. Strasser A, Harris AW, Cory S (1993): *Oncogene* 8, 1–9.
294. Yunis JJ, et al. (1982): *N Engl J Med* 307, 1231–1236.
295. Tsujimoto Y, et al. (1987): *Proc Natl Acad Sci USA* 84, 1329–1331.
296. Pegoraro L, et al. (1984): *Proc Natl Acad Sci USA* 81, 7166–7170.
297. Ngan BY, Chen-Levy Z, Weiss LM, Warnke RA, Cleary ML (1988): *N Engl J Med* 318, 1638–1644.
298. Cleary ML, Smith SD, Sklar J (1986): *Cell* 47, 19–28.
299. Davidson WF, Giese T, Fredrickson TN (1998): *J Exp Med* 187, 1825–1838.
300. Shiloh Y (2003): *Nat Rev Cancer* 3, 155–168.
301. Elson A, et al. (1996): *Proc Natl Acad Sci USA* 93, 13084–13089.
302. Barlow C, et al. (1996): *Cell* 86, 159–171.
303. Xu Y, et al. (1996): *Genes Dev* 10, 2411–2422.
304. Schaffner C, Stilgenbauer S, Rappold GA, Dohner H, Lichter P (1999): *Blood* 94, 748–753.
305. Schaffner C, Idler I, Stilgenbauer S, Dohner H, Lichter P (2000): *Proc Natl Acad Sci USA* 97, 2773–2778.
306. Stilgenbauer S, et al. (2000): *Ann Oncol* 11, 127–130.
307. Vorechovsky I, et al. (1997): *Nat Genet* 17, 96–99.
308. Bain G, et al. (1997): *Mol Cell Biol* 17, 4782–1491.
309. Voronova AF, Lee F (1994): *Proc Natl Acad Sci USA* 91, 5952–5956.
310. Hsu HL, Wadman I, Baer R (1994): *Proc Natl Acad Sci USA* 91, 3181–3185.
311. Winandy S, Wu P, Georgopoulos K (1995): *Cell* 83, 289–299.
312. Sun L, et al. (1999): *J Clin Oncol* 17, 3753–3766.
313. Sun L, et al. (1999): *Clin Cancer Res* 5, 2112–2120.
314. Sun L, et al. (1999): *Proc Natl Acad Sci USA* 96, 680–685.
315. Nakayama H, et al. (1999): *Cancer Res* 59, 3931–3934.
316. Nakase K, et al. (2000): *Cancer Res* 60, 4062–4065.
317. Olivero S, et al. (2000): *Br J Haematol* 110, 826–830.
318. Takanashi M, et al. (2002): *Br J Haematol* 117, 525–530.
319. Tonnelle C, Calmels B, Maroc C, Gabert J, Chabannon C (2002): *Leuk Lymphoma* 43, 29–35.
320. Fujii K, et al. (2003): *Br J Haematol* 120, 986–989.
321. Nakase K, et al. (2002): *Exp Hematol* 30, 313–317.
322. Yamada Y, et al. (1998): *Proc Natl Acad Sci USA* 95, 3890–3895.
323. Mao S, Neale GA, Goorha RM (1997): *Oncogene* 14, 1531–1539.
324. Mao S, Neale GA, Goorha RM (1997): *J Biol Chem* 272, 5594–5599.
325. Boehm T, Feroni L, Kaneko Y, Perutz MF, Rabbitts TH (1991): *Proc Natl Acad Sci USA* 88, 4367–4371.
326. Neale GA, Rehg JE, Goorha RM (1995): *Blood* 86, 3060–3071.
327. Larson RC, et al. (1994): *Oncogene* 9, 3675–3681.
328. Aplan PD, et al. (1997): *Embo J* 16, 2408–2419.
329. Xia Y, et al. (1991): *Proc Natl Acad Sci USA* 88, 11416–11420.
330. Aplan PD, et al. (1992): *Blood* 79, 1327–1333.
331. Curtis DJ, Robb L, Strasser A, Begley CG (1997): *Oncogene* 15, 2975–2983.
332. Condorelli GL, et al. (1996): *Cancer Res* 56, 5113–5119.
333. O'Neil J, Billa M, Oikemus S, Kelliher M (2001): *Oncogene* 20, 3897–3905.
334. Donehower LA, et al. (1992): *Nature* 356, 215–221.
335. Jacks T, et al. (1994): *Curr Biol* 4, 1–7.
336. Lozano G, Liu G (1998): *Semin Cancer Biol* 8, 337–344.
337. Krug U, Ganser A, Koeffler HP (2002): *Oncogene* 21, 3475–3495.
338. Maehama T, Dixon JE (1998): *J Biol Chem* 273, 13375–13378.
339. Myers MP, et al. (1997): *Proc Natl Acad Sci USA* 94, 9052–9057.

340. Myers MP, Tonks NK (1997): *Am J Hum Genet* 61, 1234–1238.
341. Cantley LC, Neel BG (1999): *Proc Natl Acad Sci USA* 96, 4240–4245.
342. Suzuki A, et al. (1998): *Curr Biol* 8, 1169–1178.
343. Di Cristofano A, Pesce B, Cordon-Cardo C, Pandolfi PP (1998): *Nat Genet* 19, 348–355.
344. Marsh DJ, et al. (1998): *J Med Genet* 35, 881–885.
345. Liaw D, et al. (1997): *Nat Genet* 16, 64–67.
346. Marsh DJ, et al. (1997): *Nat Genet* 16, 333–334.
347. Lowsky R, et al. (1997): *Blood* 89, 2276–2282.
348. Reitmair AH, et al. (1995): *Nat Genet* 11, 64–70.
349. de Wind N, Dekker M, Berns A, Radman M, te Riele H (1995): *Cell* 82, 321–330.
350. Ricciardone MD, et al. (1999): *Cancer Res* 59, 290–293.
351. Cline MJ (1994): *N Engl J Med* 330, 328–336.
352. Whiteside D, et al. (2002): *Cancer Res* 62, 359–362.
353. Hartley KO, et al. (1995): *Cell* 82, 849–856.
354. Takata M, et al. (1998): *Embo J* 17, 5497–5508.
355. Walker JR, Corpina RA, Goldberg J (2001): *Nature* 412, 607–614.
356. Li GC, et al. (1998): *Mol Cell* 2, 1–8.
357. Gu Y, et al. (1997): *Immunity* 7, 653–665.
358. Yang H, et al. (2002): *Science* 297, 1837–1848.
359. Xia F, et al. (2001): *Proc Natl Acad Sci USA* 98, 8644–8649.
360. Friedman LS, et al. (1998): *Cancer Res* 58, 1338–1343.
361. Lens D, Matutes E, Catovsky D, Coignet LJ (2000): *Leukemia* 14, 427–430.
362. Foroni L, Panayiotidis P, Hoffbrand AV (1998): *Br J Haematol* 100, 800.
363. Garcia-Marco JA, et al. (1996): *Blood* 88, 1568–1575.
364. Wooster R, et al. (1995): *Nature* 378, 789–792.
365. Stern MH, et al. (1993): *Oncogene* 8, 2475–2483.
366. Virgilio L, et al. (1994): *Proc Natl Acad Sci USA* 91, 12530–12534.
367. Laine J, Kunstle G, Obata T, Noguchi M (2002): *J Biol Chem* 277, 3743–3751.
368. Virgilio L, et al. (1998): *Proc Natl Acad Sci USA* 95, 3885–3889.
369. Gritti C, et al. (1998): *Blood* 92, 368–373.
370. Cordon-Cardo C, Prives C (1999): *J Exp Med* 190, 1367–1370.
371. Grabstein KH, et al. (1994): *Science* 264, 965–968.
372. Bamford RN, Battiata AP, Burton JD, Sharma H, Waldmann TA (1996): *Proc Natl Acad Sci USA* 93, 2897–2902.
373. Onu A, Pohl T, Krause H, Bulfone-Paus S (1997): *J Immunol* 158, 255–262.
374. Tagaya Y, et al. (1997): *Proc Natl Acad Sci USA* 94, 14444–14449.
375. Fehniger TA, et al. (2001): *J Exp Med* 193, 219–231.
376. Baldassarre G, et al. (2001): *Proc Natl Acad Sci USA* 98, 7970–7975.
377. Proulx GM, et al. (2003): *Am J Clin Oncol* 26, 6–11.
378. Cuadra-Garcia I, et al. (1999): *Am J Surg Pathol* 23, 1356–1369.
379. Lin CW, et al. (2003): *Lab Invest* 83, 55–64.
380. Lu LM, Hiai H (1999): *Jpn J Cancer Res* 90, 1218–1223.
381. Weissman IL, Anderson DJ, Gage F (2001): *Annu Rev Cell Dev Biol* 17, 387–403.
382. Melchers F, Rolink A (1999): In Paul WE (Ed), *Fundamental Immunology*, 4th ed. Lippincott-Raven, Philadelphia, pp 183–224.
383. Knowles DM (2001): In Knowles DM (Ed), *Neoplastic Hematopathology*, 2nd ed. Lippincott Williams & Wilkins, Philadelphia, pp 93–227.
384. Schattner EJ, Casali P (2001): In Knowles DM (Ed), *Neoplastic Hematopathology*, 2nd ed. Lippincott Williams & Wilkins, Philadelphia, pp 43–92.
385. Fischer A, Malissen B (1998): *Science* 280, 237–243.
386. Ceredig R, Rolink T (2002): *Nat Rev Immunol* 2, 888–897.

Queries in Chapter 14

- Q1. As meant?
- Q2. Define?
- Q3. Define?
- Q4. define?
- Q5. define?
- Q6. OK?
- Q7. Throughout please check italic for genes
- Q8. Define?
- Q9. Define?
- Q10. Give author(s)
- Q11. Please complete